

Oxygen, Temperature and Water content inside materials



- ▶ Sensor for continuous monitoring surveys. This is an important feature in comparison with similar sensors on the market
- ▶ Designed specifically for non-stop measurements in extremely severe situations as in industrial composting plants
- ▶ Featuring all the technical improvements acquired by LSI LASTEM experience since year 2003 in measurements inside industrial composting plants
- ▶ Sensors versions with different outputs: Radio, 4...20 mA and RS485
- ▶ Thanks to the radio technology, easy movement of the sensors from a compost line to another. No cable will disturb the operation
- ▶ Optional data management solutions: data logger, software, communication devices, actuators, etc
- ▶ DQA340.1 specific sensor for biofilters: temperature and water content measurements with a light and handy probe

Sensors range for monitoring the following parameters in compost heaps during the bio oxidation process:

- Temperature (N.2 depths)
- Temperature and Oxygen
- Temperature and Water volume

These sensors are particularly rugged and have been designed to be used in corrosive materials during continuous measurements. Thanks to a stainless steel shaft the sensors can be firmly inserted inside the material until the desired depth. Four types of outputs are available:

- Wireless version (via 869 MHz radio)
- Analog (0...1 V DC)
- Analog (4...20 mA)
- Digital (RS485 Modbus)

All outputs are available to be received and managed by LSI-LASTEM data acquisition systems.

Models

Parameters	Output Radio (869,450 MHz)	Output 0...1 V DC	Output 4...20 mA	Output RS485 (Modbus-RTU)
N.2 Temperature (H.2 m)	EXP830 EXP830.4		EXP420	EXP485
Temperature+O₂ (H.2 m)	EXP831		EXP421 EXP422	EXP486
Temperature+Water volume		DQA340.1	EXP427	

Technical specifications

	Radio (869,450 MHz)	4...20 mA	RS485 (Modbus-RTU)
Output	Radio	2x4...20 mA	RS485 Modbus RTU, TTY
Radio frequency	869.450 MHz	NA	NA
Canalization	25 kHz	NA	NA
Radio transmission power	25±3 mW	NA	NA
Radio transmission distance (line-of-sight)	600 m	NA	NA
Radio bit rate	9600 bps	NA	NA
Transmission rate	10 min	NA	NA
Radio antenna	Housed inside box	NA	NA
Configuration	Via Dip. switch	NA	Via RS232 by Terminal Emulation program
Battery	AA 3.6 V non rechargeable lithium battery	NO	
Battery file	>2 years	NA	
Power supply	Battery	9...30 V AC/DC EXP427: 9...24 V DC	
Consumption	<10 µW stand-by 250 mW during transmission	< 0.4 W	
Signal and power supply connector	NO	Waterproof male connector for DWA3xx cables	
Radio receiver	EXP301, output RS232	NA	
Output values	<ul style="list-style-type: none"> Parameters Battery voltage % battery charge 	Parameters only	
Electrical protections	NO (electrically insulated system)	Against power supply polarity inversion; electrostatic discharge on sensors line and power supply line	Against power supply polarity inversion; electrostatic discharge on sensors line and on RS485 communication line

Technical Specifications

Oxygen EXP831-421-422-486	Sensitive element	Electrochemical cell
	Measuring range	0...25%
	Accuracy	0.3%
	Resolution	0.01%
	Response time (T63)	40 s
	Output long term drift	<10% of signal/year
	Cell operative life time	3...4 months (T<50 °C), replaceable by the user
	Calibration	By user
	Operative temperature	-20...75 °C (for short periods [about 6h] with accuracy reduction in oxygen measurement)
Temperature EXP831-421-422-486 EXP830-420-485-485.4 EXP832	Sensitive element	Pt100
	Measuring range	0...100 °C
	Accuracy	±0.5 °C @ T _{env} =25 °C
	Resolution	0.03 °C
	Response time (T63)	80 s
	Operative temperature	-20...70 °C (sensor surface temperature)
Temperature and Water Volume EXP427	Measuring range (% Vol.)	0...100% water volumetric content
	Measuring range (Temp.)	-40...70 °C
	Sensitive element (% Vol.)	TDR (Time-Domain-Reflectometry)
	Accuracy (% Vol.)	@ 0...40%: 2,5%, @ 40...70%: 3.5%
	Repeatability (% Vol.)	±0.3%
	Resolution (% Vol.)	1%
	Measuring volume (% Vol.)	Ø 160x100 mm
	Operative temperature	-15...50 °C (sensor surface temperature)
General information	Protection	IP66
	Dimensions	Read pag. 6
	Weight	8 kg 6.4 kg (EXP832) 13 kg (EXP830.4)
	Materials	Electronic box: reinforced polyester Shank: AISI304
	Mounting	Vertical insertion using DYA500 handle Using DYA105 well (EXP427 only)



- ▶ TDR (Time Domain Reflectometry) technology
- ▶ Volumetric water content (%) and soil temperature measurements
- ▶ Very good accuracy: < 2%
- ▶ Half meter cubic volume for water content definition
- ▶ Buriable in the biofilter





DQA340.1 is the ideal solution for the measurement of temperature and volumetric moisture (0-100%) in biofilters. The sensor is based on TDR technology (Time Domain Reflectometry), ensuring good accuracy even in very wet soil. Using its plastic shaft, the sensor can be inserted in the material.

Technical Specifications



PN	DQA340.1	
Moisture	Principle	TDR (Time domain reflectometry)
	Measuring range	0...100% volumetric water content
	Accuracy	@ 0...40%: ±2%, @ 40...70%: ±3%
	Repeatability	±0.3%
	Sampled volume	0.25 l ± 110x50 mm diameter
Temperature	Operative Range	-15...50 °C
	Measurement Range	-40...70 °C
	Accuracy	± 0.5 °C relative
General Information	Power supply	7...24 V DC
	Power consumption	Sleep: 5 mA, Measuring: 175 mA @ 7 V DC
	Power-up time	3 s
	Output	2x0...1 V
	Operating temperature	-15...50 °C
	IP protection	Waterproof sealed PVC
	Cable	L=4 m + male connector for DWA5xxA and DWA3xx cables
	Dimensions	Body: 1135 x Ø32 mm. Rods: length: 110 mm
	Data logger compatibility	E-Log, Alpha-Log (using ALIEM module)
	Mounting	Vertical insertion using DYA106 well

Accessories

	DYA500	Removable handle with bayonet plug for sensor insertion in material. Not available for EXP427 and DQA340.1.
	DWA301	Cable L= 5 m for connection of 4...20 mA output versions to M-Log (ELO009) data logger with Mini-DIN connector
	DWA310	Reinforced cable L= 10 m
	DWA325	Reinforced cable L= 25 m
	DWA326	Reinforced cable L= 50 m
	DWA327	Reinforced cable L= 100 m
	DWA505A	Cable L=5 m
	DWA510A	Cable L=10 m
	DWA525A	Cable L=25 m
	DWA526A	Cable L=50 m
	DWA527A	Cable L=100 m
	DEC254.R	Omni-directional antenna for EXP301-401-304-820 units
	DWA601A	Serial cable L=10 m. for connection of EXP301 to E/M-Log data logger RS-232 port
	MGO510	AA 3.6 V spare battery for wireless versions
	MGO513	NiCd 9 V spare battery for EXP301 receivers, EXP401 repeater, EXP820 transmitters
	EXP301	Radio signal receiver from radio sensors or from EXP820 RS-232 Output compatible with data loggers (M/E-Log) <ul style="list-style-type: none"> • Maximum number of receivable sensors 200 • Battery NiCd 9 V • Power supply 12 V DC • Antenna included
	EXP402	"Store and forward" repeater for radio signals, version IP65. Power supply 12 V DC through DWA310 cable
	DYA056	Support EXP301-401-402 to pole D=45...65mm
	DEA251	Power supply IP65/230Vac->13,8Vcc/IP65/10W/N.2 users
	DYA059	Support DEA251 to pole D=45...65mm
	EXP304	Radio receiver/converter from radio sensors or EXP820 and conversion into 4...20 mA signals corresponding to received measures <ul style="list-style-type: none"> • Radio frequency 869,450 MHz • Outputs N.8 (4...20 mA) • Power supply 12 V DC • Batteries Litio, 3.6 V
	EXP820	Radio transmitter of 4...20 mA signals to EXP301 receiver connectable to data logger or EXP304 Receiver reconverting signals into 4...20 mA signals <ul style="list-style-type: none"> • Radio frequency 869,450 MHz • Inputs N.4 (4...20 mA) • Power supply 12 V DC
	EXP821	Radio transmitter as EXP820 but for Pt100 and 0...1 V signals Inputs N.2 (Pt100), N.2 (0...1V)

	DYA057	Support for EXP304-820-821 to pole
	DEA421	Signal converter for 0...1 V. Output: 4...20 mA Power supply 85...264 V AC Power supply for external sensors: 12 V For more technical information, see MW9008 catalogue
	MDMMA1010.1	Signal converter for 0...1 V. Output: RS-485 Modbus-RTU Power supply 9...30 V AC For more technical information, see MW9008 catalogue
	DYA105	Stainless steel well for EXP427
	DYA106	Stainless steel well for DQA340.1
	DQA340.2	Spare part electrode for DQA340.1 (one piece)
	DWA301.1	Cable to connect DQA340.1 to M-Log (ELO009), L=5 m
	ML3391.R	O ₂ cell (replacement) for EXP831-421-486 sensors
	SVSKA1002.1	Spare temperature sensor T1 for EXP830
	SVSKA1002.2	Spare temperature sensor T2 for EXP830
	SVSKA1003	Spare temperature sensor for EXP831
	MAGFA2001	Cage for fixing and protecting DQA340.1 sensors water content in biofilters

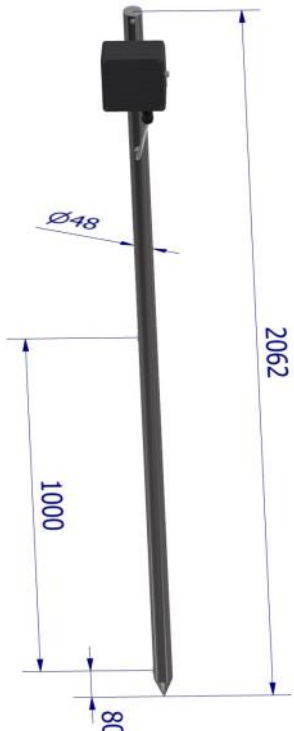
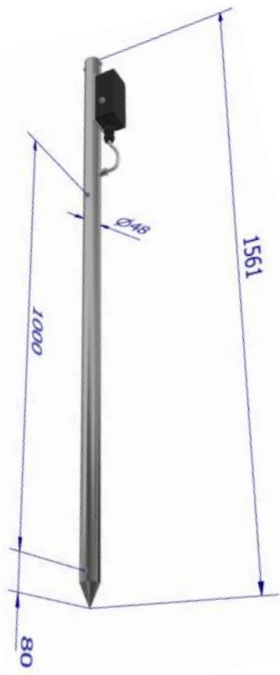
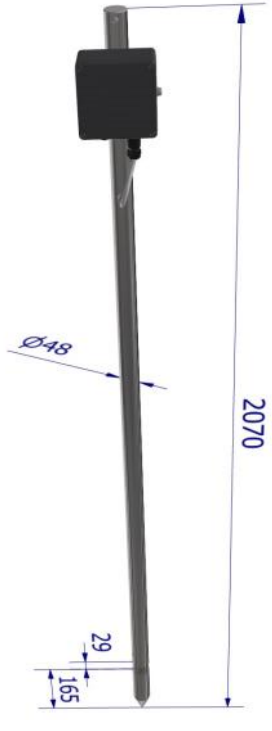
Dimensions

			
N.2 Temperature (H.2 m): EXP830-420-485 (H.4 m): EXP430.4	N.2 Temperature (H.1.5 m): EXP832	Temperature + O₂ (H.2 m): EXP831-421-486 (H.1,5 m): EXP422	Temperature + Water content (H.2m): EXP427

Signals communication

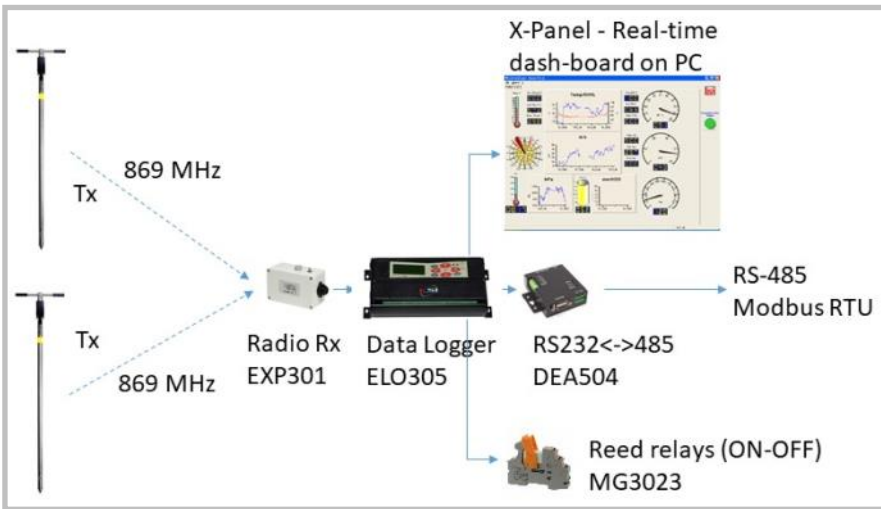

Radio signals (*) to Data Logger

Radio signals (*) are transmitted, through a radio receiver (EXP301), to ELO305 data logger. On data logger side there are several possibilities:

- Local Data storing for data reporting
- Real-time data on PC's dash-board
- Instant (or mobile statistical) values by RS485-Modbus RTU protocol
- Up to n.7 ON-OFF outputs using external reed relays with programmable activation logics

* Data logger can receive also 4...20 mA and RS485 signals.

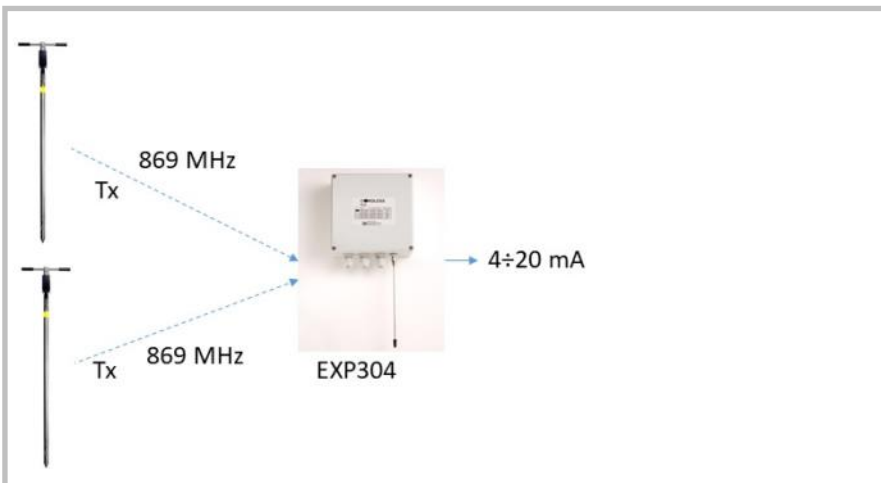

Radio signals to 4...20 mA

Radio signals are transmitted to a receiver (EXP304) equipped with 4...20 mA output.

Max. distance between radio sensors and EXP304 device is 600 m (line-of-sight).

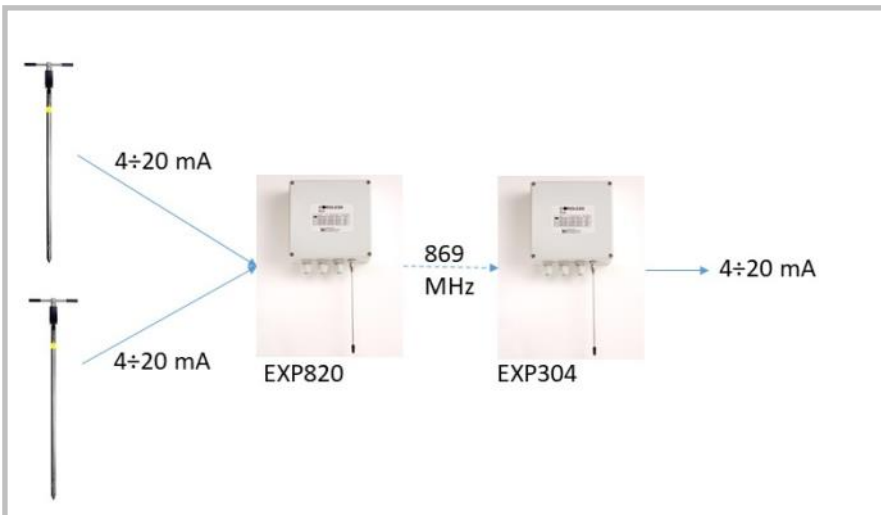

4...20 mA signals radio-transmission

4...20 mA signals supplied by the sensors are transmitted through a radio transmitter (EXP820) to a radio receiver (EXP304), where the 4...20 mA signals will be again available. Max. distance between EXP820 and EXP304 devices is 600 m (line-of-sight).



► *EXP sensors range has been specially designed for their application in industrial composting plants, waste treatment plants and wherever the environmental conditions are severe. Comparing to most of the similar sensors on the market, EXP sensors are designed for monitoring applications, where the sensor need to measure non stop for several weeks.*



► *EXP sensors range are also suitable for measurements inside Bio-filter beds*