



E-Log

User manual



Document E-Log – User manual
Pages 68

Revisions list

Issue	Data	Description of changes
21	21/06/2021	General revision based on a new board called “HW V3”
22	30/06/2022	Added description of wind processing elements and accuracy in the technical specifications; removed blank pages
23	28/10/2022	Added references to video tutorials
24	23/12/2022	Updated technical specifications. Added references to video tutorials
25	13/07/2023	Added chapter with table of supported protocols based on firmware version; added chapter on the use of 2-wire current sensors (current loop); made minor changes

Notes about this manual

The information contained in this manual may be changed without prior notification. No part of this manual may be reproduced, neither electronically nor mechanically, under any circumstance, without the prior written permission of LSI LASTEM.

LSI LASTEM reserves the right to carry out changes to this product without timely updating of this document.

Copyright 2021-2023 LSI LASTEM. All rights reserved.

Table of contents

1	General safety rules	5
2	Foreword.....	6
2.1	Disposal	6
2.2	How to contact LSI LASTEM.....	6
3	Guide to the start.....	7
3.1	Mechanical and electrical installation	7
3.1.1	Instrument power supply	8
3.1.2	Inputs and actuators	10
3.1.3	Single-ended inputs.....	13
3.1.4	Considerations on the use of 2-wire current sensors (current loop)	14
3.1.5	Serial communication lines	14
3.1.6	Modem power supply	15
3.2	Configuring the operative modes	17
3.2.1	Language configuration.....	17
4	Instrument use	18
4.1	Frontal panel overview	18
4.2	Using the keyboard.....	19
4.3	Display information	20
4.3.1	Product presentation window.....	20
4.3.2	Instantaneous values of measures	20
4.3.3	Diagnostic information.....	21
4.3.4	Shutting off the display	27
4.4	LEDs	27
5	E-Log additional features	28
5.1	Starting and running the survey	28
5.1.1	Checking the power supply voltage	28
5.2	Acquisition and calculation of measures	29
5.2.1	Acquisition from sensors with serial or radio output	29
5.2.2	Acquisition from thermocouples.....	30
5.2.3	Details about the measure acquisition process.....	31
5.2.4	Acquisition from status signals.....	31
5.2.5	Fast acquisition mode of the measures	32
5.2.6	Activation of sensor control	32
5.2.7	Details about calculated measures	33
5.3	Measure elaboration	34
5.3.1	Vectorial calculations specific for anemometric quantities.....	35
5.4	Storing elaborated data.....	37
5.4.1	Memory autonomy	37
5.5	Actuation logics	38
5.5.1	Eolic alarm.....	38
5.5.2	Evaporimeter filling.....	39
5.5.3	Start precipitation alarm	39
5.5.4	Flood alarm	39
5.5.5	Threshold value compare.....	40
5.5.6	Timer.....	43
5.5.7	Snow level alarm	43
5.5.8	System error.....	43
5.6	Communication modes	44
5.6.1	Serial port 1 – RS-232.....	44
5.6.2	Serial port 2 – RS-232/RS-485	45

5.6.3	Comparing of the serial lines facilities.....	46
5.6.4	Communication devices	47
5.6.5	TTY.....	48
5.6.6	Modbus	48
5.6.7	Biral	49
5.6.8	Data transmission through GPRS connection.....	49
5.6.9	ASCII format transmission using TCP/IP	51
5.6.10	E-Log connected like master/slave mode	52
5.6.11	E-Log with ZigBee radio	53
5.7	Operating at low energetic consumption	57
6	Appendixes.....	58
6.1	Technical feature.....	58
6.2	Function library for derived calculations	62
6.3	Error messages	64
6.3.1	Disabling error indication	65
6.3.2	Error found in measure	65
6.4	Instrument maintenance	65
6.5	Mask of terminal board	66
6.6	Connection cables	67
6.7	Supported protocols.....	68

1 General safety rules

Please read the following general safety rules in order to avoid injuries to people and to prevent damages to the product or to products that may be used in connection with it. In order to avoid damages, use this product exclusively according to the instructions herein contained.

Installation and maintenance interventions are to be exclusively carried out by authorized and skilled people only.

Install the instrument in a clean, dry and safe place. Humidity, dust and extreme temperatures may deteriorate or damage the instrument. In such cases, we advise installing the instrument inside a suitable container.

Power the instrument in a suitable manner. Connect the instrument to the power supply indicated in the model in your possession.

Carry out all connections in a suitable manner. Pay strict attention to the connection diagrams supplied with the instrument.

Do not use the product in case of suspected malfunction. In case of suspected malfunction, do not power the instrument; contact authorized technical support immediately.

Before every maintenance of electrical connections, power supply, sensors and computer-equipments:

- disconnect the power supply.
- discharge the electrostatic discharges touching one conductor or one earth apparatus.

Do not use the product in the presence of water or condensing humidity.

Do not use the product in a potentially explosive atmosphere.

Internal lithium battery. Do not replace the battery with wrong type. Possible explosion risk.

For safety regulations please refer to manual INSTUM_05290.

2 Foreword

E-Log is a data logger for environmental applications. Due to its low consumption, the range of signals it is able to receive, its protection against difficult environmental conditions and possible excess voltage, it is particularly suitable to carry out measures in meteorological and hydrologic applications, air quality, internal and external environmental monitoring.

E-Log can be fitted with a wide range of accessories to enhance its power autonomy, to protect it against extreme weather conditions and for data transmission via RS-232/485, USB, Ethernet, modem PSTN/GSM/GPRS.

2.1 Disposal

E-Log is a highly electronic scientific device. In accordance with the standards of environmental protection and collection, LSI LASTEM advises to handle E-Log as waste of electrical and electronic equipment (WEEE). It is therefore not to be collected with any other kind of waste.

LSI LASTEM is liable for the compliance of the production, sales and disposal lines of E-Log, safeguarding the rights of the consumer. Unauthorized disposal will be punished by the law.



Dispose of the dead batteries according to the regulations in force.

2.2 How to contact LSI LASTEM.





In case of problems contact the LSI LASTEM technical support at *support@lsi-lastem.com*, or fill in the *Online technical support request* form accessible from the home page of the website *www.lsi-lastem.com*.

For further information:

- Telephone +39 02 95.414.1
- Address Via ex S.P. 161 Dosso n. 9 - 20049 Settala, Milano
- Home page www.lsi-lastem.com
- Sales info@lsi-lastem.com
- After-sales service support@lsi-lastem.com, (repairs) riparazioni@lsi-lastem.com

3 Guide to the start

Watch the following video tutorials related to the topics of this chapter.

#	Title	YouTube link	QR Code
2	Powering E-Log	#2-Powering E-Log - YouTube	
3	Connection to PC	#3-E-Log connection to PC and new instrument in 3DOM program list - YouTube	
4	Sensors configuration	#4-Sensors configuration using 3DOM program - YouTube	
6	Sensors wiring	#6-Sensors wiring report by 3DOM program - YouTube	
7	Sensors inputs	#7-Sensors inputs - YouTube	

3.1 Mechanical and electrical installation

E-Log is able to be used for both internal use (placed on a flat surface or fixed onto a wall) and external use (inside suitable protection boxes).

Picture 2 shows the numeration of the frontal terminal board: connect to terminal board there are the signals sent by the sensors, the actuation signals to power external devices and the terminal connections to power the instrument (power supply or battery). The terminal board is protected by a carter (Picture 1) that covers the terminals: remove it by pressing slightly on both sides while simultaneously pushing it upwards.



Picture 1

The connectors of the serial communication lines are on the left-hand side; the socket for the external power supply connection and the instrument's power switch are on the right-hand side.

The different E-Log models have fixed or extractable terminals; in this case put an implement under the edge and prize it to extract the terminals from their housing.

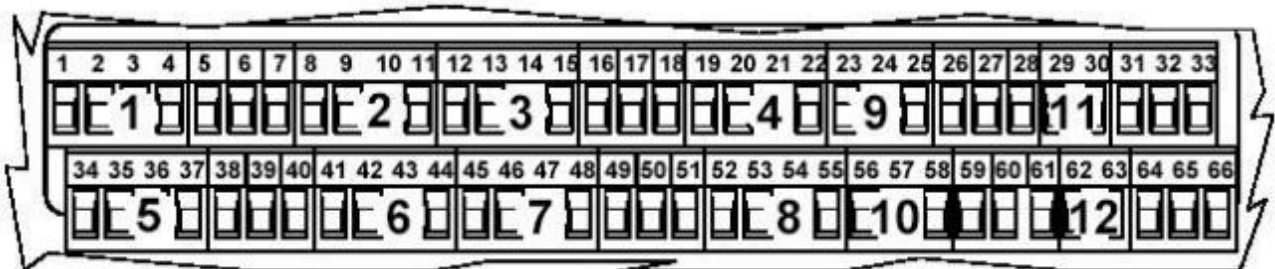

Picture 2

3.1.1 Instrument power supply

Please refer to the table below for the inbound power terminal connections to the instrument and outbound to the sensors or devices that need to be powered.

Line	Connection	Terminal
<i>Inbound</i>	0 Vdc battery	64
	+ 8÷30 Vdc battery	65
	GND	66
<i>Outbound</i>	+ Vdc fixed to power sensors/external devices	31
	0 Vdc	32
	+ Vdc actuated to power sensors/external devices	33

All models may also be powered by an external power supply by means of the connector located on the right-hand side panel; in this case the positive pole is the one inside the connector. In any case pay attention not to invert the power polarity (although the instrument is protected from wrong procedure).

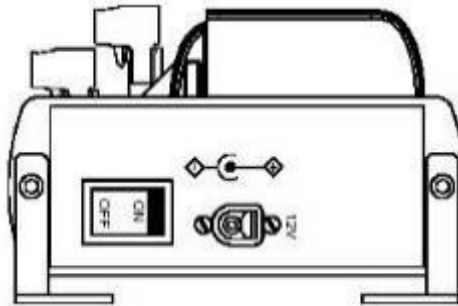

Picture 3

Whenever available, connect the ground wire (GND) to terminal 66. If the round wire (GND) isn't available, you make sure to connect terminals 60 and 61 (short circuit). This measure will improve the immunity from electromagnetic noises and the protection from induced and conducted electrical discharges.
In order to use E-Log data logger with low energetic consumption modality see §0

WARNING: in case the 31 and 32 terminals feed outside equipments, they must be equipped with power fail circuit against short circuits or absorbed currents above 1A.

3.1.2 Inputs and actuators

The instrument is fitted with 7 actuators used to power the sensors connected to the terminal board, (4 actuators for 8 analogue inputs in *differential* mode and 16 in *single-ended* mode (§3.1.3), 2 actuators for 4 digital inputs, 1 actuator for other functions); the actuators can also be used by the actuation programmable logics, than can produce alarms according to the values acquired by the sensors . The voltage available on these terminals depends on the kind of power supply received by the instrument.

Use the program *3DOM* (see SWUM_00339 available on www.lsi-lastem.com website) to configure the operation to switch on the sensors by means of the switching powers. In order to choose the actuation time is advisable to consider both the energetic saving and the time the sensor needs to initialize.

The association between input and switching power is fixed, as shown in the table below. The number of the terminal is indicated in italics; we understand, for example, that inputs 1 and 2 both make use of the first actuator; therefore, it cannot be used for the other inputs. In case of sensors that generate two signals (like the thermo-hygrometric sensor), it's suitable to select both inputs that use the same actuator.

TERMINAL BOARD								
Analogue input	Signal				GND	Probe switched power		
	A	B	C	D		Number	+V	0V
1	<i>1</i>	<i>2</i>	<i>3</i>	<i>4</i>	<i>7</i>	1	<i>5</i>	<i>6</i>
2	<i>8</i>	<i>9</i>	<i>10</i>	<i>11</i>				
3	<i>12</i>	<i>13</i>	<i>14</i>	<i>15</i>	<i>18</i>	2	<i>16</i>	<i>17</i>
4	<i>19</i>	<i>20</i>	<i>21</i>	<i>22</i>				
5	<i>34</i>	<i>35</i>	<i>36</i>	<i>37</i>	<i>40</i>	3	<i>38</i>	<i>39</i>
6	<i>41</i>	<i>42</i>	<i>43</i>	<i>44</i>				
7	<i>45</i>	<i>46</i>	<i>47</i>	<i>48</i>	<i>51</i>	4	<i>49</i>	<i>50</i>
8	<i>52</i>	<i>53</i>	<i>54</i>	<i>55</i>				

Digital input	Signal			GND	Probe switched power		
	E	F	G		Number	+V	0V
9	<i>23</i>	<i>24</i>	<i>25</i>	<i>28</i>	5	<i>26</i>	<i>27</i>
10	<i>56</i>	<i>57</i>	<i>58</i>				
11	-	<i>29</i>	<i>30</i>	<i>61</i>	6	<i>59</i>	<i>60</i>
12	-	<i>62</i>	<i>63</i>				
				<i>28</i>	7	<i>33</i>	<i>32</i>

The following pictures explain in detail the connections of all types of sensors, both analogue and digital.

Sensors with analogue signal (in differential mode):

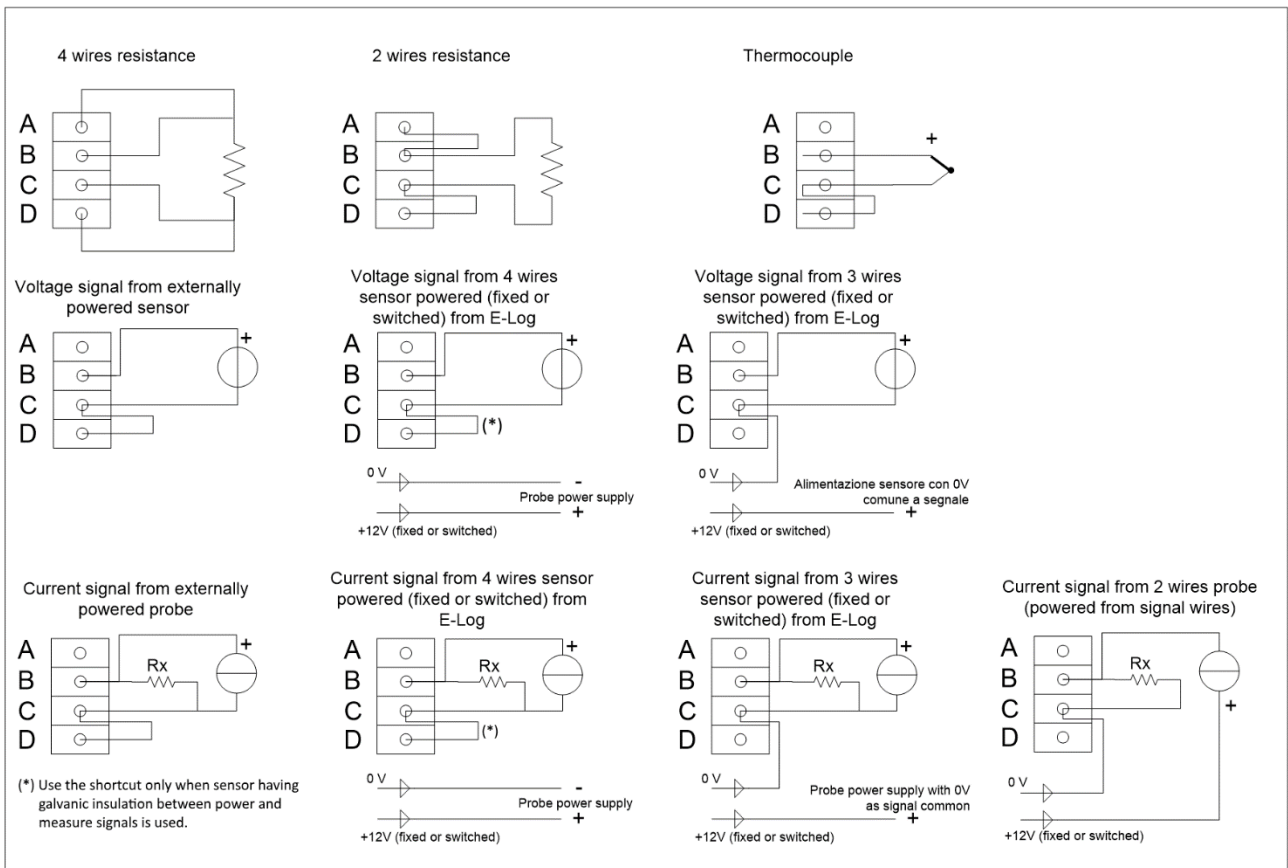

Picture 4

The drop resistance, indicated by Rx, is used to return a voltage signal from the current generated by the sensor. Program 3DOM supplies a library for the setting of the LSI LASTEM sensors, including some powered outputs; for such models the settings have been arranged to use the energized scale -300÷1200 mV, thus being able to use 50 Ω drop resistances.

Sensors with digital signal:

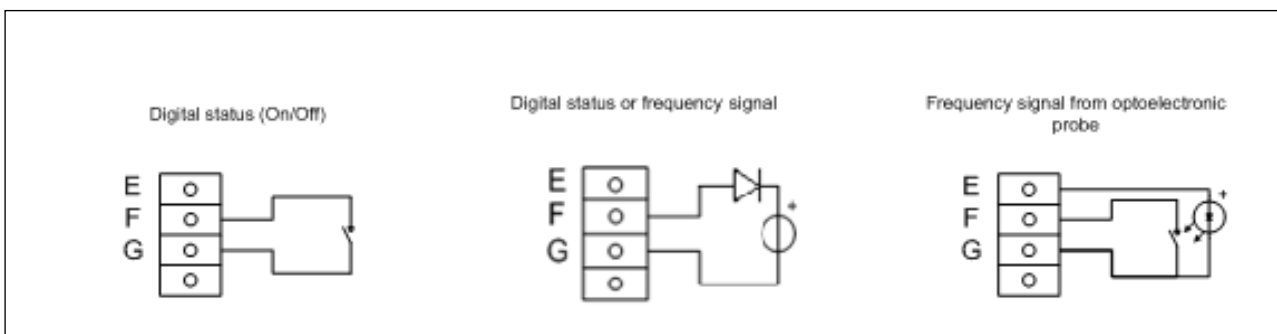

Picture 5

Picture 6 shows an example of a connection for a PT100 temperature sensor and a sensor powered by an energized output.

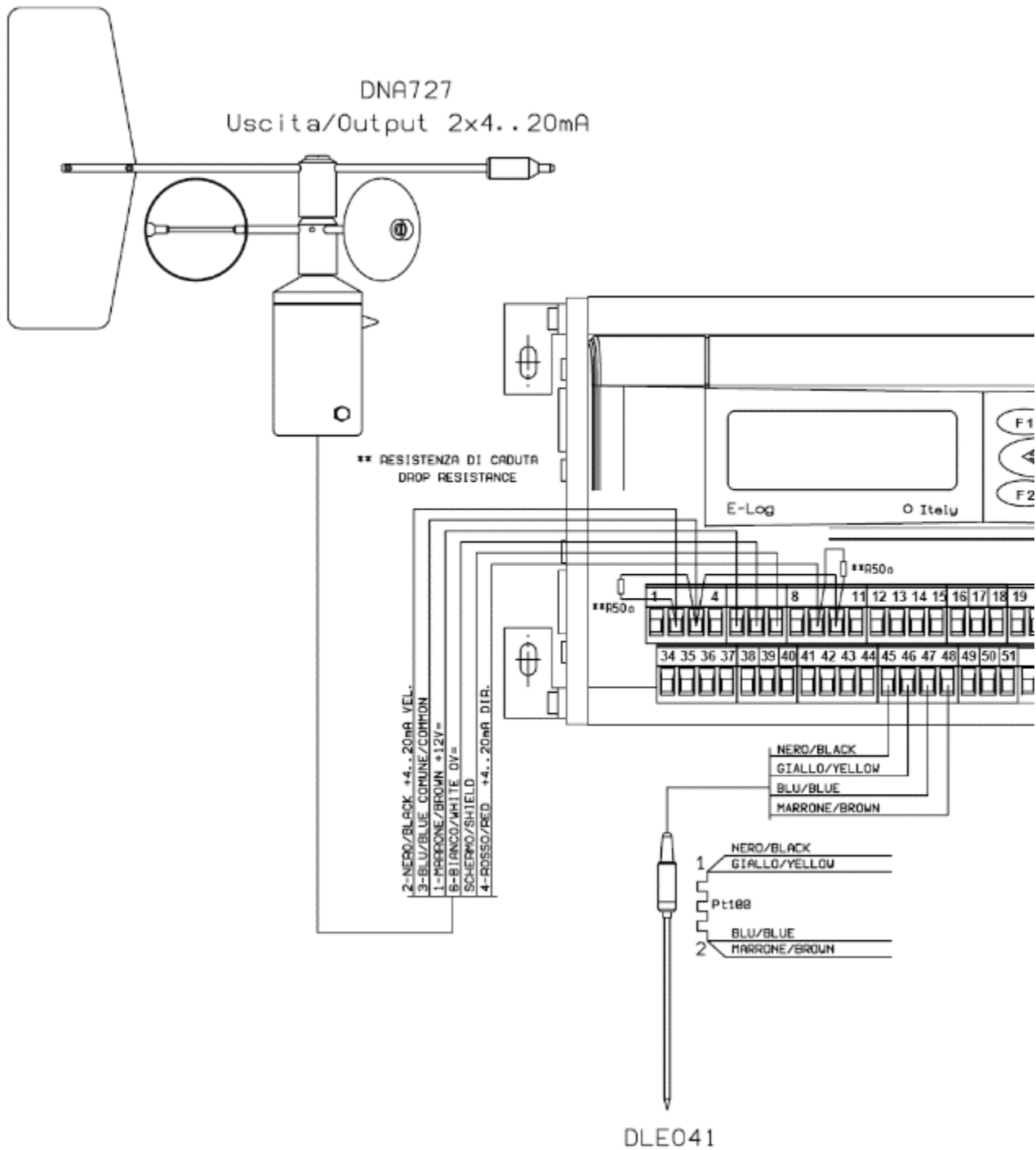

Picture 6

Moreover, if you want to connect to E-Log some LSI LASTEM portable probes (type BST, BSU, BSO...) or sensors not branded LSI LASTEM which mount minidin connectors, you have to use ELA115 interfaces for analogue sensors and ELA117 interfaces for impulsive sensors. See §6.5 for drawings and connection diagrams of their union cables.

3.1.3 Single-ended inputs

Starting from version 2.20.00 it is possible to double the number of analogue inputs, passing from 8 to 16. This function is available only for sensors with tension or current signals (this function is called *single-ended*). Resistive signals, instead, go on occupying a full single physical input (this function is called *differential*).

Differential inputs are best immune from electromagnetic disturbances than single-ended ones and, when possible, they have to be preferred.

All sensors generating tension or current signals, with or without external power, can be connected to single-ended inputs (see connection scheme).

Sensors with analogue signal (single-ended mode):

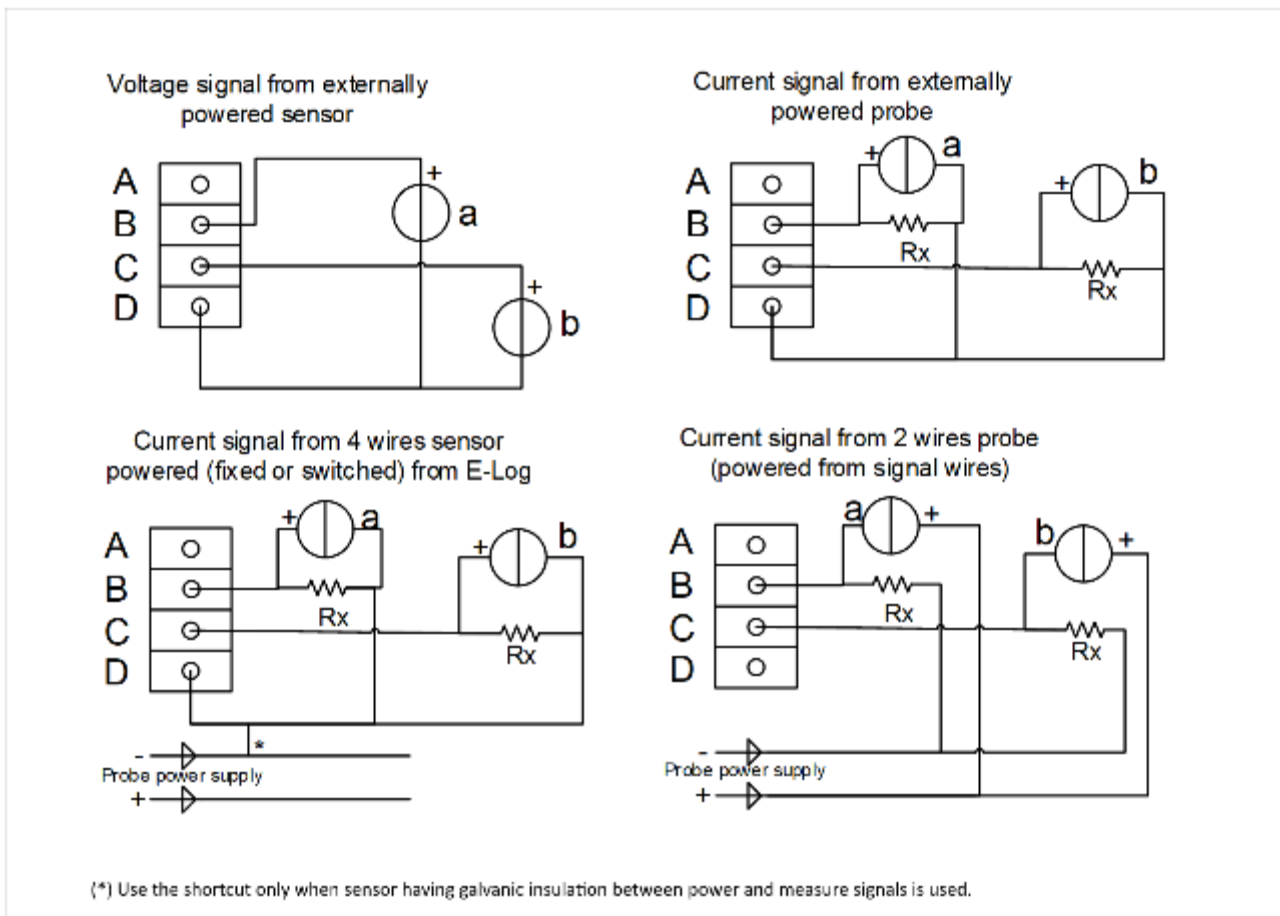

The drop resistance, indicated by R_x , is used to return a voltage signal from the current generated by the sensor. Program *3DOM* supplies a library for the setting of the LSI LASTEM sensors, including some powered outputs; for such models the settings have been arranged to use the energized scale $-300 \div 1200$ mV, thus being able to use 50Ω drop resistances.

When a probe is added using the *3DOM* probes library, those sensors are always added in differential mode; for this reason is not possible add a single-ended probe to a configuration where there is only one single-ended sensor free; when this situation occurs set the measure parameters manually matching the single-ended probe needs; otherwise change, if possible, different measures from differential to single-ended mode until obtaining a complete differential input free (two single-ended sequential inputs).

3.1.4 Considerations on the use of 2-wire current sensors (current loop)

When using current sensors with 2-wire connection, which require power supply via the same connection as the measurement signal (current loop), it is advisable to consider the voltage drop given by the total resistance placed in series with the current circuit (that relating to the data logger measurement circuit added to that of any other utilities for the measurement of the same signal) in order to evaluate whether the sensor is powered with the correct voltage in all operating conditions.

Suppose, for example, that we have a sensor that requires a minimum supply voltage of 12 V DC and that we have connected it to the E-Log terminals where the 50 Ω resistor is connected (as indicated in the data logger manual) and suppose that E-Log supplies a voltage of 12.5 V on the same terminals. When the sensor measurement is close to the full scale, the value of the current signal also reaches the full scale, therefore about 20 mA; in that measurement condition the voltage drop approaches 1 V and this value causes the sensor to be powered with a voltage of about 11.5 V, a value not compatible with the minimum operating requirements of the sensor; this situation can sometimes be difficult to identify, since any sensor malfunction or measurement error can occur sporadically, only under certain measurement conditions. If it is estimated that the above operating conditions exist, implement one of the following possible solutions:

- Reduce the value of the resistor used in series with the circuit; consequently, modify the scale parameters configured in the data logger; however, this determines the reduction of the resolution obtained from the measurement of the current.
- Increase the power supply voltage of the data logger, respecting the limits of both the data logger itself and the sensors connected and powered via its terminal block. The power supply voltage available at the E-Log terminals corresponds to that of the power supply reduced by the voltage drop determined by an internal protection diode (about 0.6 V).
- Power the sensor with an additional power source having a higher output value than the one provided by the data logger.

3.1.5 Serial communication lines

ELO3305 is fitted with two RS-232 serial ports through 9-pole female standard connectors (DB9F). Serial port 1 (located on the left-hand side panel, at the bottom near the terminals) is used to program the instrument's operative modes and data download, by means of the *LSI LASTEM CISS* communication protocol. Serial line 2 is used for communication with other devices.

Both RS-232 serial ports leave our factory with the following default configuration:

- Baud rate: 9600 bps
- Data bit: 8
- Stop bit: 1
- Parity: None
- Network address: 1
- Flow control: RTS signal only

The instrument can be programmed; however only the *baud rate* and *network address* can be changed; all other parameters cannot. The rate can be programmed from 1200 to 115200 bps; in case of use of phone modem GSM/GPRS, or a DEA550 communicator, 9600 bps baud rate and hardware flow control (RTS/CTS) must be chosen.

Electrically speaking, both ports are configured as a DCE device. The following table shows the meaning of each serial connectors' pin:

	Signal	Pin
RS-232 serial port	TD	2
	RD	3
	GND	5
	RTS	8
	CTS	7

The ELO3305.1 model has RS-485 serial line 2 instead of RS-232. The DEA602 DB9 adapter/terminal block, shown in the figure, is supplied for connecting the RS-485 devices.



It must be connected as per the following table:

	Signal	Pin
RS-485 serial port	D+ / Data+	2
	D-/Data-	3
	GND	5

The activation of the RS-485 serial port takes place by means of the 3DOM software.

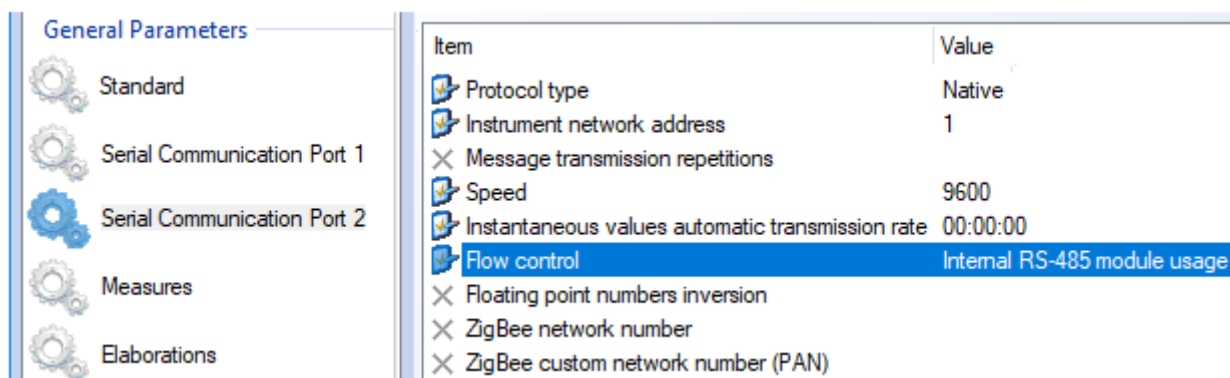

For more information on using the program, refer to the user manual SWUM_00286.

The ELO3515 model, on the other hand, has only the serial line 1 since the serial line 2 is replaced by the radio.

3.1.6 Modem power supply

E-Log can power the modem continually (through 12 Vdc powering from the terminals, like shown at §3.1.1), or through timed actuator, in order to reduce the electric energy consumption of the system.

You must use actuator n. 7, to power the modem through actuator. Activate it according to the different connected modem:

- GSM Modem: the actuator is started at time of instrument starting; in this case the telephone connection holds on also during the remote re-configuration of the instrument through *3DOM* program; the next shutdown happens by means of the timed actuation logic, according to the programmed shutdown time; i.e. in case of following programmed timed logic, starting at 15:00 o'clock and shutdown at 16:00 o'clock, if the instrument is started at 14:30, the effector will operate one hour and half;
- GPRS Modem: the actuator is started at time of instrument starting and the shutdown happens about one minute later; next modem activation will happen according to the GPRS data transmission timing, as programmed with *3DOM*.

3.2 Configuring the operative modes

LSI LASTEM supplies the instrument with a standard configuration. In order to modify the configuration parameters to one's specific needs, connect a PC to serial port 1 and run program *3DOM*; the serial port 2 can be used for configuration upload only when it is configured to use CISS protocol. Please refer to the help file of the program to know more about parameter configuration. See §3.1.5 for hardware connection of serial ports and their configuration.



During the configuration data upload (by means of the *3DOM* program) the survey (in progress in the instrument) is closed, in order to allow to the instrument the right reconfiguration condition. At this point the measures list on the display (see §4.3.2) is replaced with the notice “Survey halted”; it means that the survey has been halted.

Note: when programming a new configuration, all data stored in the instrument's memory will be deleted. For this reason, we advise to receive on PC all data from the instrument before uploading the new configuration.

3.2.1 Language configuration

The instrument always uses English language for display messaging; for measurement texts it is factory programmed to use Italian text but this can be changed by *3DOM* configuration program.

Of the *3DOM* software, the following tutorials are available:

#	Title	YouTube link	QR Code
1	3DOM: Installation from the LSI LASTEM web site	#1-3 DOM installation from the LSI LASTEM web site - YouTube	
4	3DOM: Installation from LSI LASTEM's USB pen driver	#4-3 DOM Installation from the LSI LASTEM USB pen drive - YouTube	
5	3DOM: How to change user's interface language	#5-Change the language of 3 DOM - YouTube	

4 Instrument use

4.1 Frontal panel overview

The following picture shows the frontal panel of the instrument (model fitted with display and keyboard):



Picture 7

The upper part houses the keyboard, bright indicators (led) and the display, used to check if the instrument is working properly.

The lower part includes a carter to protect the electrical connections to the terminals located inside it; to remove it, see §3.1.

Please pay attention to ELO3515 model as the top left of the front because of the output of the radio; handle with care so avoiding forcing or bending the antenna.







4.2 Using the keyboard

The keyboard includes a series of arrow keys and two function keys. The following table summarizes the main functions of each key, contextually according to the state the instrument finds itself in.









While starting the instrument:

-  Determines the fast acquisition mode of the measures (see §5.2.5)

While showing the values of the measures:

-  Goes to the diagnostic window Type 1
-  Changes the display mode of the measure name (extended, abbreviated), of the measure unit and the number of terminal which the sensor is connected to
-  Changes the display mode of the measure name (extended, abbreviated), of the measure unit and the number of terminal which the sensor is connected to
-  Scrolls up the measure list
-  Scrolls down the measure list
-  Holds/releases measure scrolling
-  Switches the display off and on (see §0)

While showing diagnostic information:

-  Shifts to the display window of the values of the measures.
-  If applicable, it resets display data (statistics, errors and other information); in the type 5 diagnostic window, it resets the GPRS modem.
-  In the display window of the communication statistics it shifts from serial 1 statistics to serial 2 and vice versa; in the type 5 diagnostic window it shows. or hides the additional information about the GPRS modem (only LSI LASTEM technician).
-  In the display window of the communication statistics it shifts from serial 1 statistics to serial 2 and vice versa; in the type 5 diagnostic window it shows. or hides the additional information about the GPRS modem (only LSI LASTEM technician).
-  Shows the previous diagnostic window.
-  Shows the next diagnostic window.
-  In the type 5 diagnostic window it switches on the GPRS modem (in case it's switched off) and starts the data communication through GPRS.
-  In the type 5 diagnostic window it resets GPRS modem.

4.3 Display information

The following information is available on the display:

- Product presentation window;
- Instantaneous values' scrolling list of all programmed measures;
- Diagnostic information.

4.3.1 Product presentation window

When the instrument is started, the following information will appear on the display for a couple of seconds:

1	2	3	4	5	6	7	8	9	10	11	12	13	14	15	16	17	18	19	20	
L	S	I	L	A	S	T	E	M								I	t	a	l	y
E	-	L	o	g	x	x	x				V	a	a	.	b	b	.	c	c	
E	n	v	i	r	o	n	m	e	n	t	a	l		L	o	g	g	e	r	
S	N	y	y	m	m	n	n	n	n	/	u	u	u	u	u	u	u	u	u	

where:

- xxx: instrument model;
- aa.bb.cc: program release (higher.lower.build);
- yymnnnn: serial number;
- uuuuuuuu: serial number or instrument number (settled by the user).

This information are also available while the instrument is working and can be called by simply using the keyboard to select this window to be displayed.

4.3.2 Instantaneous values of measures

Each line displays the last value of a measure, be it acquired or calculated. The information is displayed as follows (one or more lines):

1	2	3	4	5	6	7	8	9	10	11	12	13	14	15	16	17	18	19	20
n	n	m	m	m	m	m	m	m	m	m	m	v	v	v	v	v	v	v	v

where:

- nn: ordinal number of the measure; it does not indicate the physical input number;
- mmmm...: completed measure name; see §3.2.1 to change this text or the language used;
- vvvvvv: value of measure; the error state is identified by the writing "Err"; the value is justified on the right.

Use navigation key  to display the abbreviated name of the measure and its measure unit.

Press key  once again to display the full name of the measured quantity and the input number the sensor is connected to; if the measure is calculated, the input number will be replaced by "-"; if the measure is acquired from the serial port, it's shown (instead of the input number) the sensor's network address (with code "A"), and the number of its channel which the measure is referred to (with code "C").

In case the instrument has been programmed with one actuation logic at last, press key  once again to display the measure's alarm condition: the note "OK" specifies that the measure hasn't caused any alarm condition, at the opposite it's shown the note "Alarm".

Use keys   to shift between formats.

4.3.3 Diagnostic information

Some diagnostic windows are used to display information about the operation of the instrument and the statistics. Diagnostic window type 1:

1	2	3	4	5	6	7	8	9	10	11	12	13	14	15	16	17	18	19	20
D	T		d	d	/	m	m	/	y	y		H	h	:	m	m	:	s	s
E	r	r		e	e	e	e	e	e	e	e								
M	e	m		m	m	m	m	k	B		W	W	w	w	w	w	w		
M	s	r		A	a	a		S	s	s		C	c	c					

where:

- dd/mm/yy hh:mm:ss: current date/time of the system;
- eeee...: numeric code, expressed in hexadecimal number, which corresponds to the 32 bits of the error window of the system; in order to decode this error, go to §6.3;
- mmmm...: data memory capacity in kB;
- wwwwww...: hexadecimal number that expresses the value of the position writing in the elaborated data memory; the starting value of this position equals to 200, whereas 128 kB of memory are used for the configuration information of the instrument; when using a 2 MB memory, this value is expanded to 1FFF; the unitary increment of this value indicates a 256 byte consumption; (*)
- aa: number of measures acquired by the inputs of the instrument;
- ss: number of acquired measures from serial port;
- cc: number of calculated measures.

(*) Since the 2.07 version of E-Log, in this position of the window, the percentage of free memory is displayed; E-Log stores the data in a circular mode and then the memory is virtually endless. The calculation is based on the availability of total memory space dedicated to data processed compared to the value transferred to PC through serial line 1; transfer operations from serial port 2 doesn't change this value; if the instrument indicates the percentage of zero, it means that the circular storage algorithm has stored the new data and has cancelled the oldest data.

By pressing the arrow  you can see the old camp which is the number in exadecimal notation that expresses the value of the position in writing in the memory of the elaborated data (with a starting value which is equal to 0).

Use key  to shift to diagnostic window type 2:

1	2	3	4	5	6	7	8	9	10	11	12	13	14	15	16	17	18	19	20
R	e	s	e	t		d	d	/	m	m	/	y	y		h	h	:	m	m
C	n		B	y	t	e						M	s	g					
R	x		a	a	a	a	a	a	a	a		b	b	b	b	b	b	b	b
T	x		c	c	c	c	c	c	c	c		d	d	d	d	d	d	d	d

where:

- dd/mm/yy hh:mm: date/time the statistic was last reset; resetting the statistical values can take place locally, (key [F2]) or remotely through a suitable PC command;
- n: number of the instrument's serial port; go to the following line with key  ;
- aaaaaaaaa: number of bytes received;
- bbbbbbbb: number of messages received;
- cccccccc: number of bytes transmitted;
- dddddddd: number of messages transmitted;

Use key  to shift to diagnostic window type 3:

1	2	3	4	5	6	7	8	9	10	11	12	13	14	15	16	17	18	19	20
C	1		A	d	d	r	x	x	x	>	y	y	y	y	y	y	b	p	s
C	2		A	d	d	r	x	x	x		y	y	y	y	y	y	b	p	s

where:

- xxx: network address of the instrument;
- yyyyy: communication rate (bit rate) of the serial port.

The character “>” shows the current serial port; for this port are valid the modification commands of the bit rate (from 1200 to 115200 bps), using the keys   .



By pressing key  the instrument will set the network address temporarily to value 1 and will carry out, after some seconds, at least one test transmission of the instantaneous values that can be checked by means of any program for terminal emulation for diagnostic purposes. **Note:** the communication values can be changed by means of keyboard but this is a transitory modify, because it's arranged to solve quickly possible communication problems with the outside equipments; in fact every time the instrument is switched on again it uses the PC's programmed configurations. Use 3DOM program to program these setups definitively.

Use key  to shift to diagnostic window type 4:

1	2	3	4	5	6	7	8	9	10	11	12	13	14	15	16	17	18	19	20
O	u	t		1	2	3	4	5	6	7									
				x	x	x	x	x	x	x									
				^															
P	w	r		y	y	y	.	y											

where:

- x: value of the single actuation output: 0 = output is inactive, 1 = output is active.
- yyy.y value of the power supply-voltage measured by the instrument (Volt);
- ^ indicates the selected actuator;

For diagnostic uses, use the keys   to shift on the selected actuator (indicated by ^ symbol) and key  to shift from switched on to switched off modes and viceversa .



From 2.13.01 firmware version it is possible to force the actuator state among to the internal logics that could change (actuators logics or sensor power supply logics); in addition to the 0 value (actuator off) and 1 value (actuator on) is shown the F letter, one for each actuator, if the forcing is active.

In practice, if the forcing is also imposed to an actuator state (that can assume 0 or 1 value) means that actuator will never be change by any internal logic (except the commands received from remote through CISS communication protocol or Modbus that have priority on F status); if the F forcing is off, the internal logic can normally change the actuator status.

The diagnostic window is so displayed:

1	2	3	4	5	6	7	8	9	10	11	12	13	14	15	16	17	18	19	20
				f	f	f	f	f	f	f									
				x	x	x	x	x	x	x									
O	u	t		1	2	3	4	5	6	7									
P	w	r		y	y	y	.	y											

where:

- ^ indicates the selected actuator; it is displayed on the *Out* line instead of the actuator number;
- f indicates the forced/fixed state of the actuator; it is activated pressing the  button; use the keys   to shift on the selected actuator; it can be assume the F value if the forcing is active or it isn't displayed if the actuator follows the programmed actuation logics.

Key to shift to the diagnostic window type 5:

1	2	3	4	5	6	7	8	9	10	11	12	13	14	15	16	17	18	19	20
G	P	R	S																
N	T	:	m	m	:	s	s		C	S	Q	:	c	c					
C	n	:	n	/	t		E	r	r	:	e	e							

where:

- mm:ss remaining time for the next programmed connection (minutes:seconds)
- cc: GSM signal quality (measurement scale starting from 0 “no signal” up to 31 “maximim signal level”);
- n: number of successful connections done (starting from the previous statistical reset);
- t: number of total connections done (starting from the previous statistical reset);
- ee: status code indicating the last detected error. Considering that the error could be detected some time ago, this is not a real time indication; please ask for LSI LASTEM technical support only in the case of real malfunction conditions and not in the case of this error indication only, that is anyway a good starting point for detecting the origin of the problem.

For further details about the understanding of these window’s data see §5.6.8.

While this window is shown, press key to arrange immediately, for diagnostic purposes, the connection with the operating centre. Press otherwise to start the modem reset immediately and to reset its connections statistic and error code indication.

The window shows the status of the GPRS modem only if the instrument’s configuration considers its use (only for serial port 1); alternatively, the display goes to the next diagnostic window.

In case the configuration considers the use of the GPRS modem, but the modem is switched off, the window shows only the note “Modem GPRS: off”, alternatively to the information above mentioned.

The key shows the extra information about the GPRS connection that are useful for LSI LASTEM technical staff:

1	2	3	4	5	6	7	8	9	10	11	12	13	14	15	16	17	18	19	20
S	:	s	s	s		R	:	r		F	S	M	:	x	x	-	>	y	y
N	T	:	m	m	:	s	s		C	S	Q	:	c	c					
C	n	:	n	/	t														

where:

- sss: number of left seconds to the next status change in the internal GPRS management system;
- r: retries left to complete the current operation;
- xx->yy: actual and next statuses of the internal GPRS management system.

If E-Log has been programmed for modem switch on and switch off, when the modem is switched off (only in this case), the following message is displayed on the first line of the window:

1	2	3	4	5	6	7	8	9	10	11	12	13	14	15	16	17	18	19	20	
M	o	d	e	m		G	P	R	S	:		O	f	f						

Key  to shift to diagnostic window type 6:

1	2	3	4	5	6	7	8	9	10	11	12	13	14	15	16	17	18	19	20	
A	l	a	r	m	:	m	m		m	m	m	m

where:

- mm: number of measure in alarm conditions, according to the status obtained by the realization algorithm associated with the same measure. The window can display max 26 alarm measures (the first in the list order).

If no actuation algorithm has been programmed, the window cannot be displayed.

Key  to shift to diagnostic window type 7 (available only for ELO3515 model):

1	2	3	4	5	6	7	8	9	10	11	12	13	14	15	16	17	18	19	20
Z	i	g	B	e	e				S	N	:	n	n	n	n	n	n	n	n
S	t	a	t	:		a	a	a	a	a		(y	x)				
P	A	N	:	p	p	p	p	p	O	C	:	o	o						
S	S	:		s	s	%		R	C	:	1	0							

where:

- ZigBee indicates the radio type mounted on the instrument (if “ZigBee#”, the radio is a low power version);
- nnnnnnnn indicates the serial number of ZigBee radio, corresponding to the lower part (less significant) of the full address of ZigBee network;
- aaaaaaaaaa indicates the radio connection status and it can take these values:
 - *Undef.*: indefinite status;
 - *Init...*: radio module in progress of initialization;
 - *Init OK*: radio module initialized successfully;
 - *Conn OK*: status of correct connection to the PAN;
 - *No Conn*: status of not established connection to the PAN;
 - *Fail*: radio module absent or not working.
- x indicates the modem status; it can take these values:
 - 0: the modem has undergone a hardware reset;
 - 1: the modem has undergone a reset caused by a watchdog (blocked program);
 - 2: connection to the PAN occurred;
 - 3: status not related to the PAN;
 - 6: master modality activated.
- y indicates the radio power on status in a Slave data logger and it can take these values:
 - W: wake status, radio is active;
 - S: sleep status, radio in low power standby mode.

It is possible switch on the radio on Slave instrument pressing  key from this window.

- *ppppp* indicates the programmed identity number of the PAN (a value from 1 to 65000);
- *oo* indicates the channel number used by the radio network (typically from 1 to 14; up to 16 if using low power radio); it appears only when PAN is connected;
- *ss* indicates the signal strenght and it is expressed as a percentage; it is the received power of the radio signal of the last instrument directly connected (not include the intermediate repeaters);
- *rr* indicates the numbers of slave type nodes remaining available for connection to the instrument (maximum 10 for master and maximum 12 for repeater); it is effective only for master and repeater.

Press  to display the second diagnostic window on ZigBee application:

1	2	3	4	5	6	7	8	9	10	11	12	13	14	15	16	17	18	19	20
Z	i	G	B	e	e		F	S	M	:	f	f							
R	S	T	:	r	r		U	C	R	:	u	u							
C	E	:	c	c		I	C	:	i	i		I	P	:	p	p			
R	T	:	t	t		D	F	:	d	d		(x	/	y)			

where:

- *ff* indicates the number of current status of the main program for managing the radio driver;
- *rr* indicates the number of occurred reset of the radio caused by the driver;
- *uu* indicates the number of answer of the radio that doesn't match with AT command sent;
- *cc* indicates the number of management errors of the radio module of the received command;
- *ii* indicates the number of invalid commands;
- *pp* indicates the number of invalid command parameters;
- *tt* indicates the timeouts waiting the answer from the radio module to the management driver;
- *dd* indicates the number of failed transmission attempts;
- *x* indicates the status of the last radio data transfer; it can take these values:
 - 0: correct transmission;
 - 2: failed transmission;
 - 22: address node not valid;
 - 33: failed confirmation of network acknowledge;
 - 34: no network connection;
 - 35: addressing of network node obtained independently;
 - 36: address of network node not found;
 - 37: network track not founded;
 - 116: data size too high for transmission.
- *y* indicates the status of detection of network address of the remote node; it can take these values:
 - 0: no *discovery* operations was required for data transmission;
 - 1: a *discovery* operation was required to data transmission;
 - 2: a *route discovery* operation was required to data transmission;
 - 3: an *address* and a *route discovery* operation was required to data transmission.

Remember that by pressing of  button in ZigBee diagnostic windows resets the radio modem (press twice consecutively in a short time) or only statistics (press once).

Key  to return again to the product presentation mask.

4.3.4 Shutting off the display

Shut off the display allows to save about 25 mW. It is therefore important to keep the display shut off whenever possible when the instrument is running on batteries with or without sun panels.

To shut off the display you can use the keyboard (see §4.2) or use program 3DOM to have it shut off; to do so, modify parameter "Characteristics – auto display shut off". By setting this parameter to Yes, E-Log will shut off the display after the keyboard remains inactive for three minutes.

4.4 LEDs

The keyboard is fitted with two bicoloured LED's which show the operation of the instrument (OK/ERR) and its communication with external devices in both directions (Rx/Tx).

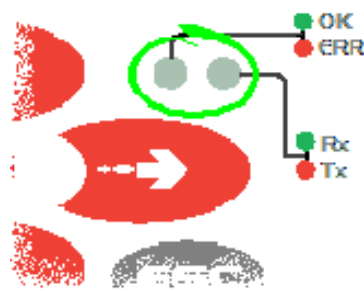

Picture 8

See below a detailed description of each state.

Status indicator	Communication indicator	Description
Off	-	Instrument switched off, or low feeding voltage (min. 7 V)
Single quick green blinking	-	Instrument switched on. Regular operation (acquisition mode)
Three quick green blinkings	-	Instrument switched on. The instrument operates in reconfiguration mode
Five quick green blinkings	-	The instrument is on. The instrument operates in quick acquisition mode
Red slow blinking	-	Instrument switched on. An error occurred. The number of blinkings indicates the type of error (see §6.3)
-	Off	No current communication
-	Green blinking	Instrument is receiving data from the serial communication lines
-	Red blinking	Instrument is transmitting data with the serial communication lines

Interval between blinking cycles: 5 s.

Quick blinking period: 125 ms

Slow blinking period: 375 ms.

5 E-Log additional features

E-Log is an instrument designed to acquire, elaborate and store measures from sensors connected to its analogue, digital and serial inputs. On the base of the acquired data it can operate field actuations according to the programmable algorithms.

5.1 Starting and running the survey

The measures and elaborations carried out by E-Log are considered as always making part of only one survey. The survey takes place automatically a couple of seconds after the instrument has been switched on. It is not possible to close the measuring and elaboration processes; in order to do so E-Log has to be turned off.

After changing the configuration, a new survey will be started. The PC's application software is used for a complete data management procedure.

5.1.1 Checking the power supply voltage

During the survey the instrument checks the power supply voltage constantly, in order to grant its enough to the inner functions. The check isn't arranged to grant the operation of the outside devices (modem, sensors that need power supply, etc.) that already couldn't work regularly.

The check happens every minute: the instrument acquires and checks the power supply voltage; it must be 7 V at least. In case it isn't enough, E-Log closes the survey in progress and stands by. During the stand-by it checks every minute the power supply voltage, until it'll reach the minimum value of 8 V. The note "Power low" (instead of the measures list) shows the stand by condition looking forward the right power supply. When the right voltage comes back, the survey is re-opened and the standard operating modes re-start.

Note: the power supply voltage is acquired and checked, even if the instrument's configuration doesn't include (among the programmed measures) the corresponding acquisition measure of the battery's voltage. In order to store the feeding values (surveyed during the survey), the battery voltage measure must be programmed (like proposed by 3DOM warning message).

5.2 Acquisition and calculation of measures

It is possible to acquire measures of sensors with a rate from 1 second to 12 hours; this allows a better representation of both fast-changing quantities (wind speed), as well as slow-changing ones (air temperature). It is possible to acquire as many as 10 measures per second.

For sensors which have to be powered, E-Log is fitted with own outputs with switched power supply (*actuators*); see §3.1.1.

The instrument is able to calculate quantities deriving from measures that sample the signs from the inputs: E-Log is fitted with a calculation library dedicated to environmental applications, also able to carry out useful mathematical functions (see §6.2). E-Log is able to acquire and calculate up to a maximum of 99 total measures. Furthermore, it's possible to program some calculated measures according to the data generated by other calculated measures.

Program *3DOM* can be used to program the measure sampling sequence: the program interface allows choosing the sequence in which the measures are displayed; hence which is the sampling sequence taking place during the survey. With *3DOM* you can also set automatically the measure sequence according to their acquisition rate (from the shortest to the slowest). This is important to gather measures which, during the acquisition process, must be sampled within the shortest intervals possible among each other (if they are allocated to only one actuator).

If configured with the same acquisition rate, the analogue channels following the first one will be sampled about 80 ms after the previous channel. This means that as many as eight analogue channels are sampled within a total time of 700 ms. Digital channels are instead sampled in about a flash.

5.2.1 Acquisition from sensors with serial or radio output

E-Log is able to acquire measures from sensors connected through serial port 2. Supported protocols are:

- LSI LASTEM CISS: owner communication protocol designed by LSI LASTEM and available in all sensors with microprocessor; medium for via radio reception by means of LSI LASTEM DEC301 outside receiver or Zigbee inside radio;
- Gill anemometers: default Gill protocol (Gill format – polar, continuous); E-Log supports the connection to one sensor.

3DOM software programs the used protocol; it isn't possible use more than one protocol (and for this reason it isn't possible connect sensors having different protocols to the serial port).

The use of CISS protocol allows the connection to one or more LSI LASTEM sensors (even if they have different model); every configured sensor must have an univocal network address as regards other sensors connected on the same communication line. The connected sensors' quantity determines the sampling minimum slot of the instrument: consider usually 3 sensors per second (the minimum acquisition time with 20 sensors must be set up 7 seconds at least). It is important that the acquisition time programmed in the instrument through *3DOM* application (shown by the parameter "*Update rate*") must be the same of the spontaneous communication rate programmed by the sensor through *LSM* program.

The sensor can be programmed to repeat the message communication several times, in order to improve E-Log reception reliability; one repeat is usually enough (so the message has been transferred twice); before the arrangement of several repeats, take into consideration: the power autonomy of the sensor (if it is powered on through battery), and the further generated traffic. This can make worse the reception reliability (depending on the connected sensors and the programmed acquisition slots).

The acquisition of messages from the sensors happens as follow: *3DOM* application programs one measure for each quantity that has been acquired and transferred inside the message by the sensor; every measure is correlate to the respective sensor’s quantity by means of the sensor’s network address, that specify: the origin sensor (in *3DOM* it’s the parameter *Probe ID*), and the ordinal number of the quantity inside the message; for example in case of LSI LASTEM mod. DME811 sensor (programmed by network ID = 5) can be programmed up to 5 different measures, which correspond to the quantity: *air temperature, relative humidity, surface temperature, temperature, temperature*. The quantities number and their programming order aren’t binding (for example it’s possible program *surface temperature, relative humidity*), but the quantities sequence must have the same order like in the message; in the previous example two E-Log measures must be programmed as follow:

Quantity	Network address	Measure index
Surface temperature	5	3
Relative humidity	5	2

In case of Gill mod. WindSonic anemometer programmed with default address (Q) the measures can be programmed in the following way:

Quantity	Network address (*)	Measure index
Wind direction	1	1
Wind speed	1	2

(*) Note: The default address of Gill sensor, equivalent to character ASCII *Q* is considered (by E-Log) like value 1; the next letter *R* like value 2, and so on.

3DOM application automates some configuration operations by means of its sensors library: for example to program the LSI LASTEM mod. DME810 sensor press key *Add* from the measures list window and then select the relevant code from the available sensors list: the application knows that sensor is serial type and so it requires the sensor’s network ID; in succession the procedure generates all needed measures for the sampling of the sensor in the right way.

5.2.2 Acquisition from thermocouples

E-Log is able to acquire the signals from many types of thermocouples. E-Log uses the internal temperature value as reference of value of the cold junction.

In these cases it is necessary to program, by means of the *3DOM* program, the measure of the internal temperature. The measure of the internal temperature must precede, in the measure sequence, all measures of quantities which use such reference.

5.2.3 Details about the measure acquisition process

The sampling of the signals produced by the sensors connected to the instrument's terminal board takes place according to the following logical procedure:

- 1) Measurement of the electrical signal based on its type (voltage, resistance, frequency, etc.) and its digital conversion into a 16-bit numeric value; the physical type of the sensor is programmed through parameter *Electrical measure type*;
- 2) Data validation: during this operation the value is limited within the scale values allowed by the physical type of measure;
- 3) Possible thermocouple value correction through the measure of the cold junction temperature (internal temperature of the instrument);
- 4) Linearization of non linear signals based on the setting of parameter *Linearization type*; the linearization may also take place through the setting of a polynomial function whose factors are specified until 10° degree (section *Linear parameter* of *3DOM*);
- 5) Recalculation of the value according to numeric parameters defined in section *Parameters*:
 - Computation of the measured quantity through the defined initial and final scale values;
 - Application of the calibration factor of the specific used sensor (radiometers, rain gauges, etc.);
 - Selection of the logical state with reference to the analogue signal thresholds;
 - Measure validation after processing accompanied by error indication if greater (by 0.5%) than the limits set in output; wind direction and relative humidity are excluded;
 - Linearized quantity control: the instrument produces null output when receiving null input.

All above parameters are indicated in section *Measure properties* in the measure modification window of program *3DOM*.

5.2.4 Acquisition from status signals

E-Log is able to acquire different types of digital status; they have to be configured for their connection to 9, 10, 11 and 12 inputs.

There are 3 different signal types: frequency signals, digital status and counters.

The default configuration of acquirer has been made for:

give logical status = 1	In case of short circuit or 0 V
give logical status = 0	In case of opened contact or 3 V

Furthermore, if one configuration for low power consumption is selected:

- For signals with frequencies over 1000 Hz it's better the input 9;
- For signals with frequencies under 1000 Hz, for counters and logical status they're better the inputs 11 and 12;
- Do not configure the input 10 because it doesn't reduce the instrument's low power consumption.

If it's been selected one configuration with no attention to power consumption:

- For signals with frequencies over 1000 Hz use the inputs 9 and 10;
- For signals with frequencies under 1000 Hz and for logical status use any inputs among the available ones.

The sensors with status output that produce voltage (i.e. they aren't pure contacts "open/closed") but with variable voltage according to measured status, can be connected to E-Log through one diode; in this way every connection is always the right one, apart from the output voltage (no divider is required). The anode of diode must be placed on clamp F of terminal board's entrance and the cathode towards the sensor.

LSI LASTEM recommended default configuration:

- input 9 for wind speed (frequency signal);
- input 10 for rain gauge (counter);
- input 11 for logical status.

5.2.5 Fast acquisition mode of the measures

For diagnostic purposes, E-Log is equipped with a function that allows the acquisition of all sensors connected to its inputs at maximum speed (excluding the sensors connected to the serial port).

This function is exclusively available during the instrument's first operating phases. Considering that in order to activate this operation mode the device must be switched off and on again, we advise to first transfer to a PC elaborations which may be present in the instruments and that have not yet been received (see §5.4).

In order to activate the fast acquisition mode press key [F2] immediately after the instrument's initial window appears, indicating among others, its serial number. When operating in this acquisition mode the instrument's LED will blink differently (see §0)

Please note that in this condition the instrument:

- Acquires all sensors and recalculates all measures every second;
- Keeps switching powers used to power the sensors permanently on;
- Uses up much more energy;
- Produces elaborations at the programmed rate; uses a higher number of samples compared to the normal conditions.

Attention: In order to set the instrument back to its normal mode, switch it off and on again without however pressing key [F2] as indicated above.

5.2.6 Activation of sensor control

The instrument acquires the sensors rapidly thus using up little energy; hence increasing its operative autonomy.

However, E-Log is able to carry out checks aimed at finding sensor failures or malfunctions and then shows an *Error* in the measured instant value. In case the check function is not activated, the possible condition of sensor interruption could cause random measures, especially in case of measures of energized signals.

This function is only applied to sensors with analogue signal. The function checks the probe's connection status at an interval that may be programmed through the *Probe check rate* parameter in the *Characteristics* window of *3DOM*.

When enabled, this function will replace the normal acquisition process. Avoid setting a check that is too frequent, especially in case of several fast rate measures. Do not use this function if you aim at saving as much energy as possible. For example, in case you have programmed 8 measures with 10-second acquisition rate, set the Probe check rate to 1 minute or higher.

5.2.7 Details about calculated measures

If the instrument has been programmed to process one or more calculated measures, the logical process will be the following:

- 1) Acquisition of all primary measures that allow the estimate of calculated measures; a calculated measure can be a primary measure for new calculated measure;
- 2) Collection of the value of primary measures; if at least one of these values is found to be in error, its calculated measure will also be indicated in error;
- 3) Collection of the value of standard parameters, whenever used in the calculation; the value of these parameters is decided during the configuration process and cannot therefore be modified during the survey;
- 4) Execution of the estimate;
- 5) Allocation of the calculated value to the measure's instant datum.

The acquisition rate of a specific calculated measure is set by *3DOM* so that it may correspond to the acquisition rate smaller than the calculated measures it depends on.

5.3 Measure elaboration

For each acquired or calculated measure it is possible to obtain statistical elaborations at a time base from 1 second to 24 hours. The selected elaboration base is common to all quantities.

Just as with the acquisition process (see §0), the elaboration process, too, evaluates the time of the built-in clock as a multiple of the elaboration rate in order to determine the moment in which the elaboration of the statistical data begins. For example, if the elaboration rate were to be set to 1 hour and 30 minutes, and the current time were 15:24:01, the following elaborations would take place at 16:30:00, 18:00:00, 19:30:00, etc.; the elaboration uses all instant data acquired or calculated in the chosen elaboration span.

The available statistical elaborations are:

- Arithmetical calculations
 - Instantaneous value
 - Mean
 - Minimum
 - Maximum
 - Standard deviation
 - Total
 - % valid data
- Vectorial calculations specific for anemometric quantities
 - Prevailing direction
 - Resulting direction
 - Resulting speed
 - Direction standard deviation (sigma-teta)
 - Calm wind percentage

It is not possible to combine arithmetical and vectorial calculations for each specific measure.

Programm *3DOM* can be used to program the elaboration parameters.

The instrument doesn't have infinite process capacity: it depends on the number of acquired and calculated measures, on programmed actuation algorithms, on processings configured for each measure, and on continuous communications between the instruments and the outside devices; all these parameters cannot be programmed at the same time up to their available maximum, because the instrument could have wrong operation. The instrument has right operation in the following heavy duty condition:

- All analogue and digital inputs configured with measures of resistance, tension, state and frequency (1 kHz); every input sampled with 10 seconds rate;
- Six measures configured like measures calculated with several algorithms;
- The remaining measures (up to 99 measures) sampled by LSI LASTEM CISS sensors with transmission every 10 seconds;
- Each measure is elaborated every 30 seconds with minimum, medium and maximum value statistics and standard deviation;
- All 20 active actuation logics configured with different algorithms and by the use of acquired and calculated measures;
- Serial communication constantly activated on both communication ports at maximum bit rate.

It's possible to *relax* some parameters in this configuration (for example the measures total number or the active actuation logics number) in order to obtain best performances in other cases (for example the measures activation slot)

5.3.1 Vectorial calculations specific for anemometric quantities

(Prevailing) average direction

It is the vector angle value calculated as the vector sum of all wind components measured by the data logger within the selected statical time base, whose module is considered unitary. It provides the most frequent origin of the wind during the processing period, regardless of the wind intensity. The formula for calculating the Prevailing average direction is as follows:

$$PrevDir = gra(\text{atan2}(\Sigma \text{Sin}(\text{rad}(\text{Dir})), \Sigma \text{Cos}(\text{rad}(\text{Dir}))))$$

Resulting average direction

Vectorial angle value calculated as the vectorial sum of all wind speed and direction components measured by the data logger within the selected statistical time base. In other words, it provides the direction of origin of the wind based even on the individual wind intensities. Below is the formula for calculating the Resulting average direction.

$$RisDir = gra(\text{atan2}(\Sigma (\text{Sin}(\text{rad}(\text{Dir})) \cdot \text{Vel}), \Sigma (\text{Cos}(\text{rad}(\text{Dir})) \cdot \text{Vel})))$$

Resulting average speed

It corresponds to the value of the modulus of the vector calculated for the evaluation of RisDir, so it is the wind intensity resulting from the sum of each individual components. In other words, from the point of view of the displacement of the air masses, the same result would be obtained in real conditions, if the wind were blowing constantly with this intensity and from RisDir wind direction angle. Below is the formula for calculating the Resulting average speed.

$$RisVel = \frac{\sqrt{(\Sigma \text{Sin}(\text{rad}(\text{Dir})) \cdot \text{Vel})^2 + (\Sigma \text{Cos}(\text{rad}(\text{Dir})) \cdot \text{Vel})^2}}{n}$$

Direction's standard deviation (sigma theta)

It is the standard deviation of the wind direction. It indicates the fluctuations of wind direction across its average value. The formula for calculating the the Standard deviation of direction is as follows:

$$StDevDir = gra\left(\text{asin}\left(\sqrt{1 - \frac{(\Sigma \text{Sin}(\text{rad}(\text{Dir}))^2 + (\Sigma \text{Cos}(\text{rad}(\text{Dir}))^2)}{n^2}}}\right)\right)$$

Calm percentage

It indicates how many times, during the processing period, the wind intensity has remained below the relative threshold set in the data logger (default: 0.3 m/s), and therefore how many times the wind direction has been excluded from the calculations of the above indices, as they are not significant. In case of total absence of wind during the processing period, CalmPerc assumes the value 100, while both PrevDir and RisDir assume the conventional value 360 (wind angle to be considered "not significant"). The formula used to calculate the Calm percentage is as follows:

$$CalmPerc = \frac{\sum^n Calm}{n} * 100$$

Where:

Dir = instantaneous value of wind direction (0 - 360 °)

Vel = instantaneous value of wind speed (m/s)

gra = conversion of an angle from radians to degrees

rad = conversion of an angle from degrees to radians

Calm = 0 in case of not calm wind speed (< 0.3 m/s), otherwise 1

n = number of considered valid original data (no error)

5.4 Storing elaborated data

E-Log stores the calculated statistical processings (elaborated data) in the 2-MB internal memory; a part of this memory (128 kB) is used for configuration information and other internal information; the real capacity is therefore slightly less than the total storage capacity.

Data storage takes place circularly; once the memory is full, the new data will replace old ones.

By sending a new configuration to the instrument, all data so far stored will be cancelled; this happens because the new configuration information might be potentially not in tune with them, and the PC might misinterpret them.

The instrument stores the data in the internal memory only when a *data page* is full; the dimension of this page equals to 256 bytes; therefore, the instrument might store the data only after several sequences of elaboration; this depends on the programmed elaboration rate, on the number of active measures and, for each one of them, on the selected elaboration elements. Please note that by switching off the instrument, some elaborated data inside the *data page* and those not definitely stored might be lost; for this reason we advise transferring the elaborations which have not yet been transmitted to the PC before switching off E-Log.

5.4.1 Memory autonomy

Depending on the chosen configuration (measures, types of elaboration for each measure and acquisition rate) the instrument will work somewhat autonomously as far as the maximum storage time is concerned, without replacing old data with new ones. The calculation of the time dimension of the maximum number of storable data is as follows:

$$A = K / (86400 / RE * NE)$$

where:

- A = number of days of autonomy of the data memory;
- K = value subordinate on the size of the used memory; for the 2 MB internal memory, K=430592 (from 2.12.00 instrument firmware version, K=415744); for the 8 MB internal memory, K=1841152;
- RE = elaboration rate expressed in seconds;
- NE = total number of elaboration's elements programmed for all measures.

5.5 Actuation logics

E-Log has got an actuation logics library. It's useful to switch-on all type devices (alarms, solenoid valves, motors) according the surveyed parameters in surrounding environment. The actuation logics are based on the instantaneous value of the acquired and calculated measures. They can be programmed up to 20 calculation algorithms, that use same or different logics. One or more algorithms can be combined in two differed modes , in order to switch-on the selected actuator:

- 1) All algorithms must be in alarm at the same time (AND logic)
- 2) One algorithm can be in alarm at least (OR logic)

The actuator's switch-on logic can operate according to *low power consumption* mode (the actuator is usually deactivated, and starts in case of alarm), or according to *safety* mode (the actuator is usually activated, and it shuts-down in case of alarm). Summarizing explanation in the table below.

Operating logic	State	Actuator
Low consumption mode	No alarm	Actuation output switched-off
	Alarm	Actuation output switched-on
Safety mode	No alarm	Actuation output switched-on
	Alarm	Actuation output switched-off

In case of one or several measures' error (for example owing to sensor breaking, no-scale acquisition, or disconnected cable) it doesn't modify the present state of the actuator piloted by the logic that uses the same measures.

The manual activation and deactivation of the actuators, performed by the user directly on the instrument from *Diagnostic window type 4* (see §4.3.3), does not affect the actuation logics. The actuation logic deactivates the actuator only if it has previously activated from the logic itself.

The actuation logic begins operation after the first activation of the actuator, even if this occurs temporally after the deactivation.

The programming of the actuation logics happen by means of the *3DOM* program according to two different phases:

- 1) Selection of the logics and their calculation parameters (section *Logics*);
- 2) Selection of the actuation outputs and their AND or OR modes correlation with the preset logics (section *Actuators*); note that the same logic can be combined with other different logics several times, in order to switch over different effectors.

5.5.1 Eolic alarm

The logic uses a wind direction measure to establish the condition of a wind position in a specified sector for a predefined time. Can be set:

- The measure that samples wind direction (degrees);
- The starting angle (extreme included) of the direction sector;
- The ending angle (extreme included) of the direction sector;
- The continuous permanence time of the wind direction inside the defined sector in order to detect the alarm condition;
- The continuous permanence time of the wind direction outside the defined sector in order to detect the end of the alarm condition.

Both times can be set from 0 seconds to 12 hours; if both times are set to zero, the wind direction in or out conditions inside the sector are immediately detected.

It is possible to join this logic with an another logic of threshold bypass type (see §5.5.5) applied to a wind speed measure: in this way it's possible to refine further the alarm activation (i.e. to activate the alarm when the wind is more than 5 m/s for at least 3 minutes and inside the *Est* sector of 45 degree for at least 1 minute).

5.5.2 Evaporimeter filling

The logic uses a water level probe inside the evaporimeter to establish the need for filling up it.

Can be set:

- The measure that samples the water level;
- The filling-up start time (it's recommended the automatic filling-up programmed in the morning, before the sunrise, in order to avoid temperature changing that could alter the evaporation measure);
- The maximum filling-up time, useful to avoid flooding in case the water level sensor is broken or surveys a wrong measure;
- The maximum water level that determines the stop of the filling;
- The minimum water level, under that the need for the evaporimeter filling-up (at the defined time), is detected. To obtain the right evaporation keep the evaporimetric basin always filled. Therefore set the minimum level like the maximum level, because, in case of too low water level, the shade of the walls on the surface of the water doesn't allow the right evaporation in the morning and in the evening.

5.5.3 Start precipitation alarm

The logic uses a measure connected to a rain gauge to detect the start precipitation conditions.

Can be set:

- The measure that samples the precipitation;
- The minimum time T1 after the first precipitation detection by means of the rain gauge (instantaneous value > 0);
- The minimum time T2 that must pass after the precipitation detection, meanwhile no precipitation is detected (no precipitation detection by the inner sensor of the rain gauge), to determinate the end precipitation condition;
- The minimum precipitation quantity that determines the start of the precipitation condition.

The alarm condition is detected when T1 time is passed after the first precipitation detection (and it's raining again), or is reached the specified rain quantity; anyway if T2 time is passed without any precipitation detection, the system goes to no alarm condition.

5.5.4 Flood alarm

The logic uses a measure connected to a rain gauge to detect flooding conditions. Can be set:

- The measure that surveys the precipitation;
- The maximum precipitation quantity in a defined period;
- The minimum precipitation quantity in the same period;
- The length of alarm or not alarm period.

The alarm condition is detected when, within the specified period that starts from the first precipitation event, the maximum precipitation quantity is exceeded; from alarm condition beginning or at the end of the first period, are managed new periods and for each of them the rain totalization starts from zero; for each

new period, if the rain fall quantity returns below the specified minimum value, the system returns in no alarm condition.

5.5.5 Threshold value compare

The logic detects value overflow or underflow by one or more measures (both univocally and simultaneously). To the threshold values can be applied a further hysteresis value; this can avoid continuous alarm state changes in case the measure value moves nearly around the threshold value. The comparison logics are the following:

- *Greater than*: alarm in case the measure value is greater than the threshold value added to the hysteresis; return to no alarm condition when the measure value is lesser than the threshold value minus the hysteresis; i.e. threshold value=4.0 and hysteresis=0.2 (alarm in shaded area):

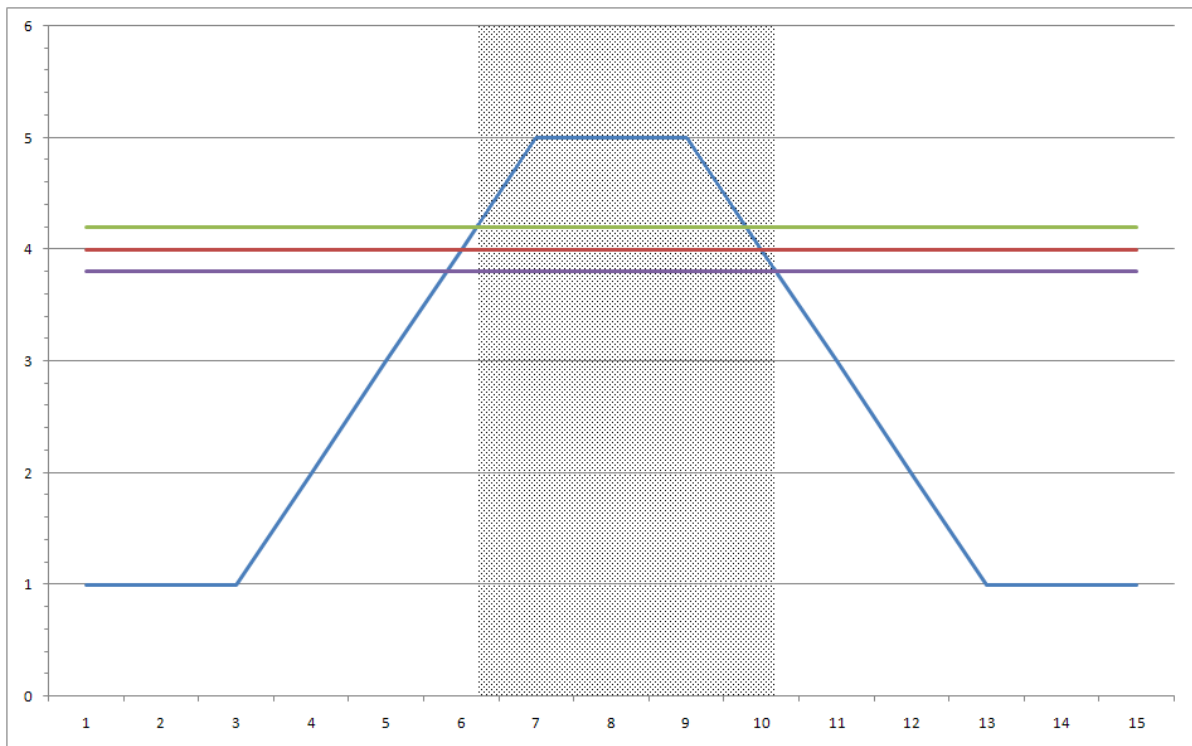

- *Lesser than*: alarm in case the measure value is lesser than the threshold value minus the hysteresis; return to no alarm condition when the measure value is greater than the threshold value added to the hysteresis; i.e. threshold value=4.0 and hysteresis=0.2 (alarm in shaded areas):

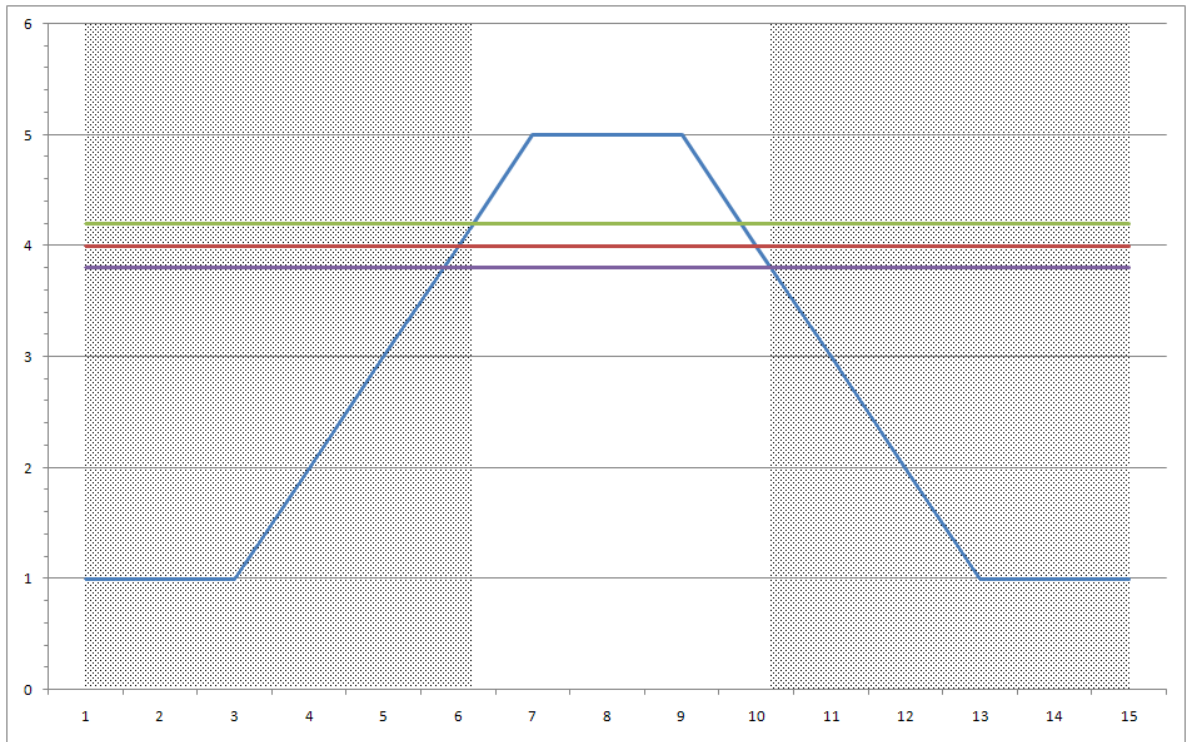

- Included:** alarm in case the measure value is greater than the minimum threshold value and at the same time lesser than the maximum threshold value; return to no alarm condition when the measure value is lesser than the minimum threshold value or greater than the maximum threshold; hysteresis is used like shown in the following example: threshold values=2.0 and 4.0 and hysteresis=0.2 (alarm in shaded areas):

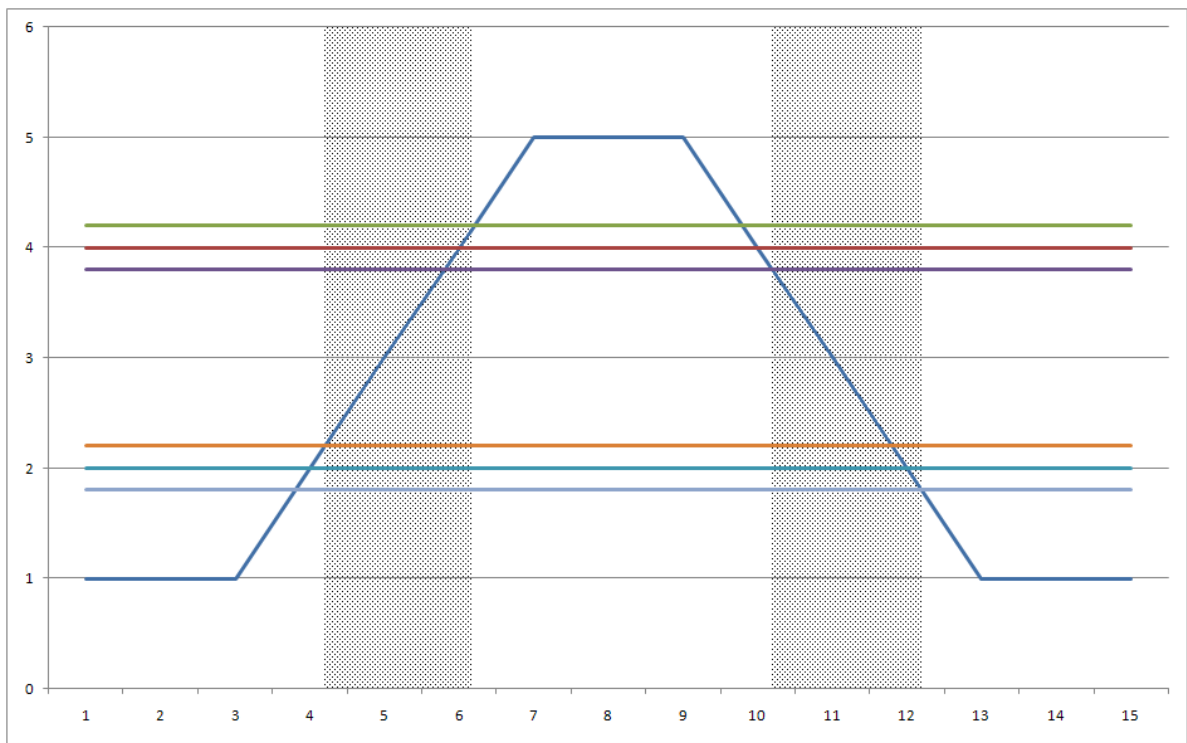

- Excluded:** alarm in case the measure value is lesser than the minimum threshold or greater than the maximum threshold; return to no alarm condition when the measure value is greater than the

minimum threshold and at the same time lesser than the maximum threshold; hysteresis is used like shown in the following example: threshold values=2.0 and 4.0 and hysteresis=0.2 (alarm in shaded areas):

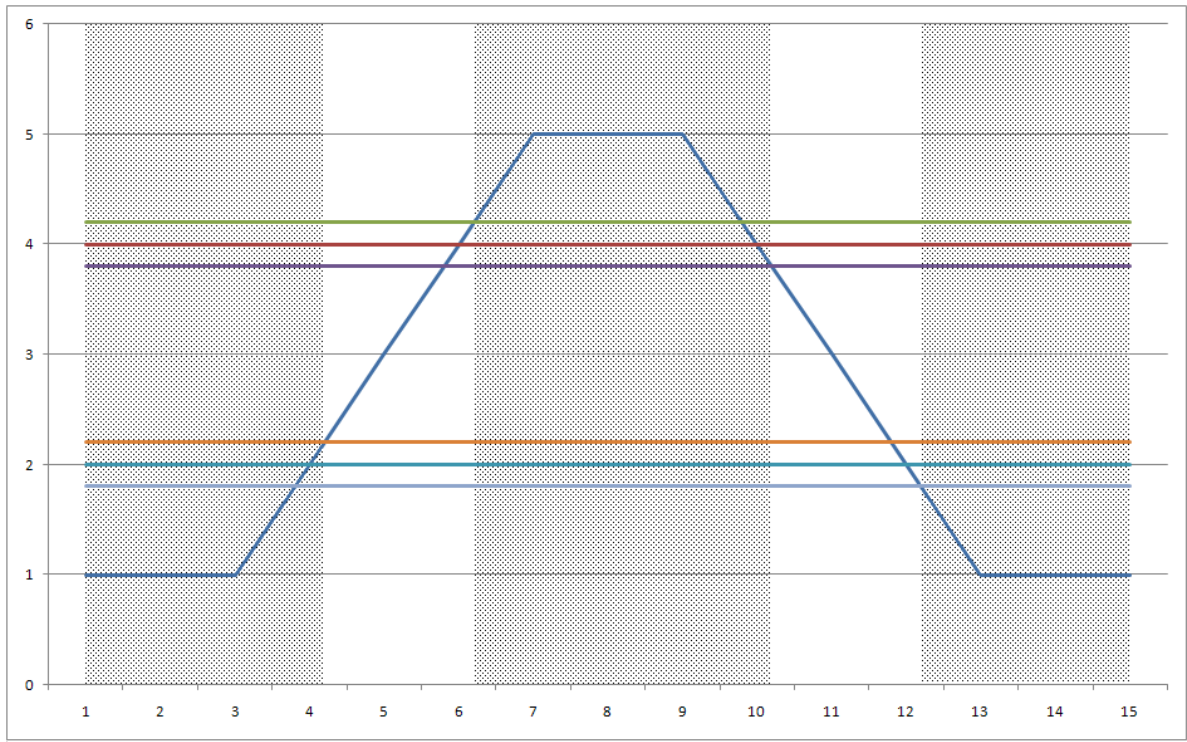

Threshold value compare algorithm can be applied to one or more measures; in the last case all used measures must be consecutively ordered (the list cannot include any measures that shouldn't be considered in the comparing), because the logic programming needs the ordinal numbers of the first and last measure. This logic can be programmed to detect the alarm condition only if all measures (that belongs to the selected set) or alternatively only one of them are contemporary over the stated limit.

Furthermore, it's possible specify a minimum time (during that the measure stays over the set threshold value) to enter into the alarm condition and a minimum time to exit from the alarm condition. It can be done applying the algorithm to only one measure (i.e. it isn't possible to program the minimum times if two or more measures have been selected).

5.5.6 Timer

The timer logic allows: to activate or deactivate the actuator in two different times in the day, or alternatively to define a timed cycle on/off status. Can be set:

- Timer type (cyclic or time);
- The power-on delay after the initial instant determined by the cycle;
- If timer type is cyclic, the on and off statuses duration; the first cycle starts in the day time when the instrument clock time, divided by the sum of the two durations, returns zero as remainder; in this way the first cycle starts in a precise day time, not at any moment (i.e. if has been programmed 15 minutes *On* period duration, and 45 minutes *Off* period duration, the first cycle starts at the first hour and zero minutes after the instrument survey is started); the next cycles happen at set on/off times.
- If timer type is not cyclic, the day time of power on the actuator, and the day time of power off.

This logic is joinable with other logics in *AND* mode, for example to allow the alarms activation only in specified hours of the day.

5.5.7 Snow level alarm

The logic detects excessive snow fall conditions in indeterminate time period; the alarms condition stays active during programmable time; at the end of this alarm period the snow level starts to be counted from the actual level; if during the alarm condition the snow level decreases (owing to melting or autocompression), the snow level start value (used like reference value in the next delta calculation) updates accordingly. Can be set:

- The measure that samples the snow level;
- The maximum delta (centimetres), over that the system goes in alarm condition;
- The alarm duration before its automatic reset.

5.5.8 System error

The logic sets an alarm when the instrument detects and internal malfunction. All errors are detected as specified in §6.3.

5.6 Communication modes

5.6.1 Serial port 1 – RS-232

E-Log interfaces with the PC by means of a non-invertible 9-poles male/female serial cable.

E-Log features a special system to activate the communication port: after 8 seconds of inactivity, the consumption drops to a first level of savings; after further 22 seconds, the consumption drops to the minimum values. When not continually requested, E-log communicates using very little energy.

Each instrument uses a network address, defined by a number between 1 (default) and 200. Whenever the instrument is networked (RS-485, radio) with other instruments, it will be necessary to change the address. PC programs use the address of each specific instrument to select E-Log to which the communication messages will be sent.

E-Log is compatible with all LSI LASTEM sensors equipped with CISS protocol. It can therefore be used in LSI LASTEM cordless sensors networks which report to E-Log, Babuc ABC acquisition instruments or receivers connected directly to a PC. In this case E-Log can be programmed to transmit instant data of acquired and calculated measures spontaneously through serial port 1 or serial port 2; this parameter can be found in the communication parameters modification window of 3DOM and is called *Instantaneous values automatic transmission rate*. In this mode E-Log is like a multichannel LSI LASTEM CISS sensor, and its measures can be received from other E-Log.

The serial port 1 can be connected with GSM or GPRS modem; in this case follow the instruction in §0 to reduce the modem power consumption. To execute local communications with E-Log remove the connection between the modem and serial port 1 and connect PC to the instrument serial port directly.

Note: when the PC has to communicate with the instrument through serial port 1, it could meet some problems to run first communication, if the serial port 1 has been programmed to execute the frequent rhythm spontaneous data transmission (rates shorter than 10 s); in this case try more times. Once the message is received, E-Log keeps the spontaneous communication deactivated 1 minute, in order to make easy the possible further communications with PC.

From release 2.04.04 of E-Log has been added one facility only referred to serial communication line 1, where the flow control can be managed according to three choices (none, only RTS, RTS/CTS) selecting through configuration from 3DOM (see §4.4.4.3 of manual SWUM_00286 available on www.lsi-lastem.com website).

The programming of option “RTS/CTS” can forbid the next communications with PC, because this one doesn’t manage the flow control like DCE computer-equipment. For communication between E-Log and PC arrange as follow:

- Through instrument’s user interface select the statistic mask that shows the communication speed of serial line and press F2: the instrument will configure all default parameters (9600 bps, id=1, only RTS, native protocol CISS) for selected serial line; this’s only temporary configuration (the instrument restores the previous configuration sent from PC to its next restart); so use this operating mode in order to re-send, through PC, one modified configuration.
- alternatively, if the instrument doesn’t have the local user interface, it’s necessary the input of one serial adapter in which the signals RTS-CTS have been bridged in E-Log connection side (pin 9 and 8 of 9 pin connector).

5.6.2 Serial port 2 – RS-232/RS-485

Serial port 2, RS-232 or RS-485 depending on the E-Log model and the firmware version (see §6.7), has different communication protocols, as follow:

- Native (CISS): reception of measures' instantaneous and processed data, instrument's personal data and diagnostic data, inner clock date/hour setting;
- CISS sensor: reading of the data sent by LSI LASTEM sensors through serial or radio output (see §5.2.1);
- Gill anemometer: data acquisition from Gill anemometers with Gill default protocol;
- TTY: it allows the simplified inquiry of the measures data, through terminal too (see §5.6.5);
- Modbus: the instrument implements the industrial Modbus RTU Master/Slave (see §5.6.6);
- Aeroqual analyzer: data acquisition from Aeroqual Analyzer;
- Hydrolab: data acquisition from Hydrolab sensors;
- Climatronics sensor: data acquisition from Climatronics AIO Compact Weather Station;
- Biral sensor: data acquisition from Biral sensor.
- Komoline sensor: data acquisition from Komoline sensor.
- Boschung sensor: data acquisition from Boschung sensor.

Some LSI LASTEM applications (like i.e. *InfoPanel*) are able to obtain the instantaneous measures data from serial port 2. In this way the serial port 1 is available to be connected to other local devices, or remote devices (by modem).

Note: in ELO3515 model equipped with built-in radio, the serial port 2 is not externally available. In this case, the only available communication protocol is the native CISS type (see first point above).

5.6.3 Comparing of the serial lines facilities

This table compares the different communication facilities available for instrument's two serial lines.

Protocol / Device	Function	Com1	Com2
(Owner) LSI LASTEM CISS	Transmission of instantaneous values of the measures (in polling mode or spontaneous transmission)	X	X
	Transmission and reset of elaborated data from memory	X	X
	Transmission of instrument registry information	X	X
	Transmission and setting of configuration parameters (measures, elaborations, communication, actuation logics, etc.)	X	X
	Transmission and reset of diagnostic information updated in real time or stored in memory (system log)	X	X
	Transmission of actuation logics state (alarms) or digital outputs state (actuators) (*)	X	X
	Transmission and setting of system date/time	X	X
	Setting of digital outputs (actuators)	X	X
	Acquisition of instantaneous values sampled from sensors with LSI LASTEM CISS protocol	X	X
	Management of system commands (start/stop survey, memory format, instrument reset, etc.)	X	X
TTY	Transmission of instantaneous values of the measures (in polling mode or spontaneous transmission)		X
	Transmission of instrument registry information		X
	Transmission and reset of diagnostic information updated in real time		X
	Setting of system date/time		X
Modbus RTU Master/Slave	Request/Transmission of instantaneous values of the measures (fixed point or floating point)		X
	Transmission and setting of digital outputs (actuators)		X
	Transmission of instrument registry information		X
	Transmission and reset of diagnostic information updated in real time		X
	Transmission and setting of system date/time		X
Aeroqual	Acquisition of sampled instantaneous values and transmission from connected instrument		X
Gill	Acquisition of sampled instantaneous values and transmission from connected instrument		X
Hydrolab	Acquisition of sampled instantaneous values and transmission from connected instrument		X
Climatronics	Acquisition of sampled instantaneous values and transmission from connected instrument		X
Biral	Acquisition of sampled instantaneous values and transmission from connected instrument		X
Komoline	Acquisition of sampled instantaneous values and transmission from connected instrument		X
Boschung	Acquisition of sampled instantaneous values and transmission from connected instrument		X

Protocol / Device	Function	Com1	Com2
ZigBee	All commands provided in owner LSI LASTEM CISS protocol		X
PSTN/GSM Modem	Available in transparent mode with any protocol	X	X
GPRS Modem	Support to communication on TCP socket (encapsulation of the only owner LSI LASTEM CISS protocol), or with FTP protocol (transmission of elaborated data in binary format)	X	
RS-232/Ethernet Converter	Available in transparent mode with any protocol or in <i>Modem emulation</i> mode	X	X (**)

(*) Function obtained by programming of appropriate calculated measures.

(**) Does not support the *Modem emulation* mode.

For further information about the supported protocols, refer to §6.7.

5.6.4 Communication devices

E-Log has different communication devices that can be used for the connection to the data collection systems:

- DEC301 radio communicator: it operates at 434 MHz frequency, has 300 m as the crow flies capacity, connection rate 9600 bps; it can be connected to PC together with an other DEC301 communicator; it can be connected both serial port 1 and serial port 2 of E-Log; reference manual: INSTUM_00067.
- ZigBee radio: it operates at 2.4 GHz frequency, it has about 100 m as the crow flies capacity; connection rate up to 115 kbps; it allows the LSI LASTEM sensors reception through ZigBee protocol; it available for some models and is included into the instrument; for these models cannot be used the serial port 2 because it is not available externally.
- BlueTooth radio communicator DEA300: works in the 2.4 GHz frequency range, data transmission up to 100 m (LOV), communication speed up to 115 kbps; it can be connected to PC using integrated or external BlueTooth adapters; connection scheme: DISACC5946, user's manual: INSTUM_00901.
- RS-232/RS-485 serial converter DEA504: it extends the connection cable up to 1 km and more; the connection speed depends on the distance; it can be connected both to serial port 1 and serial port 2 of E-Log; connection scheme: DISACC5584a.
- RS-232/Ethernet converter DEA550: it allows the connection to instrument using Ethernet LAN/WAN line, so virtually every distance; it allows the bit rate up to 115 kbps; it can be connected both to serial port 1 and serial port 2 of E-Log; it can works in *Modem emulation* mode to allow the data logger to send autonomously data to a remote server in ASCII text format.
- GSM DEA714-DEA715 modem: it connects to remote devices by means of GSM network; connection rate 9600 bps; it can be connected both to serial port 1 and serial port 2 of E-Log; DEA715 modem (using actuated signals from data logger) can be used for application where SMS are sent in case of alarm state; connection schemes: DISACC4852b (DEA714), DISACC4978a (DEA715).
- GSM/GPRS DEA717-DEA718-DEA718.1 modem: it uses the GPRS data packet transmission and TCP or FTP protocols (DEA717-DEA718 with E-Log FW until V. 2.29.00; DEA718.1 with E-Log FW V. 2.30.00 or later) to allow the continuous transmission (with transmission rate according to choice) and rating according to traffic; it can be connected only to serial port 1 of E-Log; connection schemes: DISACC5416 (DEA717), DISACC5416b (DEA718 and DEA718.1).
- Radiomodem devices DEC010/5/8/9: they permits communications at long distance (some kilometers) operating on VHF 169 MHz and UHF 868 MHz frequency ranges; they don't require government concession; user's manual: INSTUM_00757.

5.6.5 TTY

TTY protocol allows the inquiry of the data acquired by simplified way (also from terminal), or the transmission of the instantaneous data of the measures by spontaneous mode.

For more information about TTY protocol, see INSTUM_00728_en manual available on www.lsi-lastem.com website.

5.6.6 Modbus

Modbus is a serial communication protocol used in industrial circle; it allows the communication between one *master* (usually PC) and one or more *slave* (devices for measurement, check or PLC) connected to the same network. Modbus sets-up the *master* and *slave*'s modes to start and stop the communication, it settles the modes for messages exchange and errors identifying too. Only *master* can start the communication.

There are two protocol versions: one serial version (RS-232 or RS-485) and one Ethernet version. The serial version includes two different communication modes: one RTU mode (where the data are packet in Hexadecimal format) and one ASCII mode (where the data can be easily read). In Ethernet version (like the RTU version), the protocol's packets are inside TCP/IP packets.

Every network device has its univocal address. A Modbus command includes the Modbus address of the instrument which need to communicate with. Only this instrument will answer to the command, even though all instruments receive it. All Modbus commands include check information that assure the correct reception of the command. The base commands can ask to a *slave* to change one value into one of its statuses or to return one or more values included into its registers.

E-Log looks like either as *master* or *slave* and implements part of the industrial Modbus protocol in RTU version both on RS-232 and RS-485 serial port.

For more information about Modbus protocol see INSTUM_00728_en manual reported on www.lsi-lastem.com website.

5.6.7 Biral

Biral protocol allows the data acquisition from *present weather* Biral sensor. In order to decode the received data of some parameters you must follow the following tables:

OVM - Obstruction to Vision Message	
Value	Meaning
0	No obstruction
1	HZ Haze
2	FG Fog

SFM - Self-test and Monitoring			
Subparameter	Format	Value	Meaning
Sensor Reset Flag	Ooo (first digit)	0	Command "R?" received
		1	Command "R?" not received after reset
Window Contamination	oOo (second digit)	0	Window contamination is less than 10%
		1	Window contamination warning
		2	Window contamination fault
		3	Sensor input saturated
Other Self-Test errors	ooO (third digit)	0	No fault
		1	Internal error / Other self test fault
		2	Forward Scatter Receiver Flooded with Light
		3	Back Scatter Receiver Flooded with Light

The values received as "X" (temporary values after initialization, error indication) are marked by the value - 999999.

5.6.8 Data transmission through GPRS connection

GPRS data transmission system consists of the following parts:

- One or more E-Log instruments;
- One modem GPRS LSI LASTEM Mod. DEA718 or DEA718.1 for each E-log, respectively connected through ELA110 cable; the modem SIM card must be able to GPRS data transmission and the request of PIN code must be disable; (if the communicator DEA550 is used, please read the application note document AN_00938_en);
- One PC server with Windows operating system (Window XP or next version, Windows Server 2003 or next version), connected to Internet with a public IP address;
- LSI LASTEM *CommNetEG code BSZ306.2* program with use licence enabled for GPRS connections (only for transmission through TCP socket).

E-Log must be configured through 3DOM program, in order to use GPRS modem and transfer the processed data with selected timing; the GPRS modem can be used only with serial port 1. In the configuration through 3DOM software, remember to enable with *Yes* the field *Modem powered with actuator* in the *Serial communication port 1* window when the modem is powered using actuator #7 (recommended solution). It is suggested to enable the option *Modem power up mode to Switched off and on in case of failure*.

GPRS connection happens according to the spontaneous transmission rate programmed inside the system; therefore it happens according to the programmed timing (on the initiative of the instrument); you can also make a manual data transfer by pressing the button . The remote computer (that collects the data) consists of one TCP server, set on IP public address. The address of this server has been programmed inside GPRS modem connected to E-Log.

There are two different transmission's modes:

- Through TCP socket;
- Through FTP protocol.

The TCP socket connection allows to have greater control over the data logger against the FTP protocol, because not only the elaborated data transmission is supported but also some other protocol commands are allowed (i.e. real time measures value, data logger clock synchronization). Moreover, one server (no special software installed in it) can transfer the data through FTP protocol.

In addition to the above-described parameters, set all the parameters indicated by 3DOM software in according to the selected transmission's mode (i.e. APN for GPRS connectivity, remote server IP address, user name and password for FTP server access).

In case of transmission through TCP protocol the operative centre must be equipped with LSI LASTEM *CommNetEG code BSZ306.2* program. In case of transmission through FTP protocol, one FTP server must be available and working.

When using the GPRS, E-Log can have problems of a temporary nature which do not obvious lack of data on remote servers, or systemic problems that determine instead the inability to transmit part or all of the processed data. In the first case, the possible error signal, which should appear, can be ignored; in the second case, the error code may be useful for tracking the nature of the problem and to restore the functioning of communications.

Following table shows some error codes detectable by the data logger.

Error code	Status	Suggestion
6, 15, 16	Modem base initialization	Initialization commands are rejected by the modem. The data logger support only modem provided or approved by LSI LASTEM
8	Modem presence check	The modem does not respond to the data logger. Check: <ul style="list-style-type: none"> • Modem power (fixed or actuated) • Serial connection to the data logger communication port 1 Setup the data logger to use a communication speed on port 1 equal to 9600 bps and hardware flow control RTS/CTS
10	Modem setup with user parameter	Additional initialization commands are not correct; use 3DOM to check this kind of information inside the data logger configuration
17	TCP connection	Remote TCP server does not answer to the data logger request: check the access parameters (IP address and TCP port) configured inside the data logger; check the network infrastructure (router, LAN, etc.); verify the <i>CommNetEG</i> application if it is alive and ready to accept incoming TCP requests

Error code	Status	Suggestion
20	FTP connection	Remote FTP server does not accept to the data logger request: check the access parameters (IP address and TCP port) configured inside the data logger; check the network infrastructure (router, LAN, etc.); check the user name and password; check the log recorded by the FTP server
21÷27	Creating, sending and closing file	Check the log recorded by the FTP server
28, 30÷33	GPRS context creation and network access	Using 3DOM verify the APN connection parameters against the SIM used inside the modem (Access Point Name, user name and password for GPRS connection); the SIM used inside the modem must be enabled to GPRS data transmission; PIN code request must be disabled
35	TCP modem emulation connection	Remote TCP server does not answer; check the access parameters (IP address and TCP port) configured inside the data logger; check the network infrastructure (router, LAN, etc.); verify the <i>MiniCN</i> application if it is alive and ready to accept incoming TCP requests
36÷41	Creating, sending and closing file	Check the log recorded by the <i>MiniCN</i> application



5.6.9 ASCII format transmission using TCP/IP

About the possibility to program the data logger for transmitting data in ASCII format using TCP/IP, please read the application note document *AN_00938_en*. Take care of what inside §5.6.8 because still applicable with this kind of data transmission.

5.6.10 E-Log connected like master/slave mode

It's possible use two E-Log cascading, that is master/slave mode, especially when the number of physical inputs required by the application is higher than the number of physical inputs supplied by one E-Log data logger. So we call *master* instrument the E-Log connected to host through direct connection or through communication apparatus, while *slave* instrument is connected only to master instrument. Using this configuration mode the slave instrument is a real multi-parametric serial sensor (from master data logger's point of view).

In order to configure the system like master/slave mode follow the instructions below:

1. Physical connection:
 - Connect the serial port 2 of both data loggers using standard serial cable with DEA606 null modem adapter;
 - Connect the serial port 1 of E-Log master with the host through direct connection or through one communication apparatus;
2. During configuration through 3DOM software:
 - configure the slave instrument using only its measures (i.e. the measures that take-up their physical inputs) and don't setup any processing;
 - configure the master instrument using both its measures (marked with symbol ) and the serial measures (marked with symbol ) coming from slave instrument;
 - check the agreement between the measures acquired from slave and the serial measures received from master (most of all the values of *Sensor's Protocol Address* and *Index of measure in the sensor*); the uncorrect agreement prevent the master instrument from acquiring correctly.
 - for E-Log master configure in serial communication parameters of nei port 2: *Protocol Type* =sensors CISS and *Velocity*=9600;
 - or E-Log slave configure in serial communication parameters of port 2: *Network Address*=1 and *Spontaneous transmission Rate* ≠0 (input one rate lower than the acquisition rate of fast serial measure set up on master; we recommend the input of slave's transmission rate half of master's acquisition rate);
 - For serial measures, that have to be received from master instrument, set up the *Sensor's Protocol Address* equal *Instrument's Network Address* selected for serial communication port 2 of slave instrument; recommended default value is 1.

So, it will be possible the remote modification (through 3DOM software) of instrument's configuration, but it will not be possible the remote modification of slave's configuration.

5.6.11 E-Log with ZigBee radio

ELO3515 E-Log data logger with built-in ZigBee radio are especially suitable for applications where devices interact with low temporal frequency and moderate amounts of transported data (packets of several hundred bytes); they are ideal for networking many devices (up to 200) which require no communication channels in continuous time mode but the opportunity of exchanging data only on request. Furthermore, it's possible to get more data acquisition networks operating simultaneously and in parallel (without interference problems) through the allocation of different network addresses (PAN ID) in the configuration.

All E-Log with ZigBee technology inside are provided from factory with configurations already programmed in one of three possible modes (Master, Repeater, Slave) to set up a network of nodes that can communicate with each other:

- *Master* is the capital device that manages the network, connected to the host (PC) through direct connection or through communication device; it is the focal point of all the messages and acquired data.
- *Repeater* is a powered continuously device that acts as a measuring workstation and repeater of network messages when they can't directly reach the master device.
- *Slave* is a device with the feature of remaining in low-power modality for a programmable time to minimize the consumption; it's a typical for applications where the power is provided by small capacity battery (*).

ZigBee technology is commonly used with limited coverage wireless networks, capable of covering areas with a radius around the hundreds of meters. Exploiting the characteristic to configure data loggers as a Repeater, it's possible supervise a large environment by creating a network of instruments communicating with each other without the use of special communication devices (as dedicated cordless transmitter and repeater). The possibility of having multiple Repeater devices in a network allows the messages to find viable alternative routes to reach the destination with greater reliability or in case of failure of one of network's devices.

Constraints of ZigBee application are due to the distance between devices and physical obstacles (walls and ceilings for indoor applications, buildings and plants for outdoor applications) that the signal encounters during their journey to the destination of communication.

Specifications	Performances
Indoor standard range	up to 60 m
Outdoor standard range (as the crow flies)	up to 500 m
Diffused power	10 mW (+10 dBm)
Reception sensitivity	-102 dBm
Operating frequency band	ISM 2.4 GHz
Bit rate	250 Mb per seconds
Data throughput	up to 35000 bps
Number of channels	13
Transmission consumption (only radio)	170 mA
Reception consumption (only radio)	45 mA
Supported network topologies	Point-to-point, Point-to-multipoint, Peer-to-peer, Mesh
Agency approvals	Europe (CE) ETSI United States (FCC Part 15.247) FCC ID:MCQ-XBEEPRO2 Industry Canada (IC) IC: 1846A-XBEEPRO2 Australia C-Tick Japan R201WW8215142

These are operation conditions to be follow for arrangement of a network:

- In each network should be only one Master device;
- use Slave device only with energy saving requirements or inability to be fed continuously;
- the maximum number of repeaters connected in cascade is 10 (i.e. the greater physical distance in a network must be covered with 10 sectors);
- you can directly connect maximum 12 Slave devices to each Repeater;
- you can directly connect maximum 10 Slave devices to each Master device;
- in a ZigBee network you can connect maximum 200 devices (as well as for the CISS protocol).

There are two main transmission modes provided for a ZigBee network:

- *spontaneous transmission* of messages to Repeater or Slave to the Master device exploiting the potential of the network to reach the Master station even if not directly connected to the Master;
- *transmission upon request* from the Master (“polling”). The E-Log Master is connected to a call and data storage system (usually a PC) that manages communication querying all devices on the network with a timing settable by a proper software. In case of presence of subnets, in order to communicate simultaneously without interference with the Master device of the network, you must give an additional receiver apparatus each subnet (in this mode radios are always on; in order to enable the Master to have multiple paths to reach the end devices, is advisable to install radio repeater and E-Log data loggers will not go in low energetic consumption mode).

5.6.11.1 Network set-up

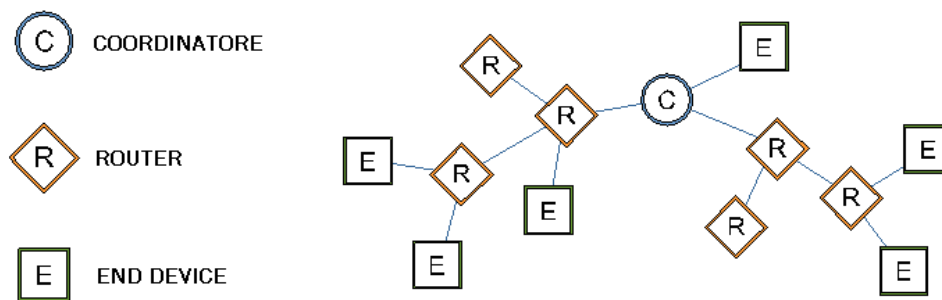

If you want set-up new generic network, in other words in case you don't know if network will include Router and End Device devices both like distribution and number, we recommend to follow the points below:

1. Distribute all nodes known topologically (depending on density and reciprocal distance) covering the area of network use through computer devices that should be connected.
 - Study the topology of place where you install the network devices.
 - Put the devices in place making attention to distance as the crow flies among respective nodes (remain within max range specified in specifications) and considering the obstacles on every distance (building works, furniture, vegetation...).
2. Check that obtained distribution could have RF coverage also on longer distances (i.e. verifying that communications are carried out correctly in every intermediate distance)
 - Check coverage in all distances using devices configured with quick acquisition/transmission rate. For each distance place the respective Router or End- Device device in installation point and go from that point away with Master device checking the coverage parameters and instruments connected to it (see §4.3.3 diagnostic mask 7).
3. Evaluate the possible End Devices in case there are needs of powers through battery
4. Evaluate Routers devices (always powered) that allow the network arrangement with End Devices. These Routers can be other devices with measurement facility, or can be exclusively dedicated for collection and transmission of messages generated by End-Device devices and their members
 - Check that all positions preset for Routers devices are equipped with 220 Vac or 12 Vdc power supply.
5. Value the redundancy obtained with all present Routers considering the possibility to have multiple paths suitable for data transmission. In practice you have to check if coverage, obtained with distribution of computers device to check, allows more than one path towards Master device. In case of paths supported only by sequence of one device at a time, the loss of an intermediate element blocks the communications, because of the lack of a possible alternative path.
 - Turn all devices provided for network on and try to simulate the shutdown of some intermediate Routers, checking on Master the right reception of messages also from the farthest devices.
6. Add Routers in case you want increase the redundancy of paths in order to give the network more than one transmission possibility.
7. Configure the sleep time of devices in order to obtain an optimal configuration with low energetic consumption mode.
 - In 3DOM for all the Routers and Coordinator, set the sleep time so that it is higher (almost twice) of the longer time programmed in any networked Slave; in order to obtain a good functioning of the network, is important that all Routers and Coordinator to share the same value; this value is irrelevant for the End Device.

The above described principle for network setup can be improved during fist network start-up, as the instruments, equipped with display, will allow the identifying of all elements that can be reach through RF and the evaluation of connection quality of signal displaying the diagnostic of device (Index SS = value from

0 to 100%; see §4.3.3). In any case an estimation of physical layout of network is useful in order to foresee the needs of further support items. Network isn't absolutely binding from point of view of present components, so you can modify the structure, through Master, any time you need it.

Note 1: in a network, in case of reprogramming of Master without modify of configuration of Slave instruments (which are turned on and active in acquisition mode), it could happen that the Slave devices are not connected to the network and data from these stations don't arrive (or arrive at different delay times). In order to restore the correct operating mode, restart the Slave devices or set the fast acquisition mode of Slave to have available quickly a great number of connection attempts to the network.

Note 2: on Slave devices it's always possible turn on manually the radio by pressing of  button from diagnostic mask 7 (the mask dedicated to ZigBee Radio). There i also a configuration parameter (programmable from 3DOM software) that determines the fixed power of radio for Slave devices (if you want to interrogate them at any time); in this case, these are supplied by means of external power supply pack (consumption about 20 mA continuous).

5.7 Operating at low energetic consumption

In order to optimize energy consumption, proceed as follows:

- Use the highest possible value to program the acquisition rate of the measures, according to the dynamic feature of the quantity's signal to be sampled (see §5.2);
- Keep the actuation time to energize the sensors low without compromising the reliability of the measure (see §3.1.1);
- Use the lowest possible acquisition time required to, however, have the sensor send the measured signal in a correct manner (see §3.1.1);
- Use a high rate, and only if necessary, to program the rate for probe control (see §5.2.6);
- When using only one high frequency pulse-type signal, it's better use input 9 rather than input 10;
- It's better use inputs 11 and 12 for rain sensors;
- Switch the display off manually or program it to automatically shut off by itself (see §4.3.4);
- Disable the fast acquisition mode of the measures which was possibly enabled while the instrument was switched on (see §5.2.5).
- Cancel not-used actuation logics (see §5.5);
- Manage modem switch on through actuator 7 (programmed with timed logic), or programming GPRS communication through modem activation (see §3.1.1);
- In case of sensors or telephone modems fed continuously, don't use instrument's batteries, but use other ones (if possible). In this way the instrument can operate even if modem and/or sensors aren't fed, and so they aren't operating;
- Disable communication protocol on serial port 2, in case it isn't used or in case it corresponds to following types: TTY, Modbus, Gill anemometer.

ATTENTION: Default configuration programmed on instrument is not the one of lowest energetic consumption.

In case of Slave devices:

- The Slave devices must have a channel to measure battery (level battery or voltage) that bypasses the internal acquisition mode, normally set at one minute. The low energetic consumption is achieved by programming the measure with a higher acquisition rate (5 minutes or more recommended).
- It's important don't turn off (accidentally or otherwise programmed) the device "parent" of the Slave because before the next attempt to send data, the Slave should enter a search mode (which still has a limited duration) that consumes a lot of energy.

6 Appendixes

6.1 Technical feature

Models E-Log

Code	ELO3305	ELO3305.1	ELO3515
Description	E-Log data logger		
Analog inputs	8 differential (16 single ended)		
Digital inputs	4 (on/off or frequency/counter)		
RS-232 serial port	2	1	1
RS-485 serial port	NO	1	NO
On/off outputs	YES	YES	YES
Radio	NO	NO	Freq: ISM 2.4GHz, Tx pwr: 10mW
Internal battery	NO	NO	Litium rechargeable 3.7 V, 2000 mAh
Included accessories	RS-232/USB adapter, RS-232 cable, DIN bar mounting	RS-232/USB adapter, RS- 232 cable, adapter for RS-485 cable wires, DIN bar mounting	RS-232/USB adapter, RS-232 cable, DIN bar mounting

Common features

Analog inputs	Type	Range	Resolution	Accuracy	
	Voltage	-300 ÷ 1200 mV	40 μ V	$\pm 100 \mu$ V (@ 25°C)	-0.2 μ V/°C (@ -10 ÷ 25 °C) +0.2 μ V/°C (@ 25 ÷ 45 °C)
		± 78 mV	3 μ V	$\pm 35 \mu$ V (@ 25°C)	-0.2 μ V/°C (@ -10 ÷ 25 °C) +0.2 μ V/°C (@ 25 ÷ 45 °C)
		± 39 mV	1.5 μ V	$\pm 25 \mu$ V (@ 25°C)	-0.2 μ V/°C (@ -10 ÷ 25 °C) +0.2 μ V/°C (@ 25 ÷ 45 °C)
	Pt100	-50 ÷ 125 °C	0.003 °C	± 0.05 °C (@ 25°C)	+0.0035 °C/°C (@ -10 ÷ 45 °C)
		-50 ÷ 600 °C	0.013 °C	± 0.11 °C (@ 25°C)	+0.0035 °C/°C (@ -10 ÷ 45 °C)
	Resistance	80 ÷ 140 Ω	0.0013 Ω	± 0.02 Ω (@ 25°C)	+0.28 Ω /°C (@ -10 ÷ 45 °C)
		80 ÷ 320 Ω	0.005 Ω	± 0.05 Ω	
		0 ÷ 6000 Ω	0.19 Ω	± 1.5 Ω	
	Thermocouples	E-IPTS 68	< 0.1 °C	± 1.5 °C	
		J-IPTS 68	< 0.1 °C	± 1.2 °C	
		J – DIN	< 0.1 °C	± 1.2 °C	
		K-IPTS 68	< 0.1 °C	± 1.9 °C	
		S-IPTS 68	0.22 °C	± 4.9 °C	
		T-IPTS 68	< 0.1 °C	± 1.4 °C	

Analog inputs (...continue)	Voltage clamping	±2.5 V
	ESD protections (complies standards)	IEC 61000-4-2 Contact Discharge ±12 kV IEC 61000-4-2 Air-Gap Discharge ±15 kV IEC 61000-4-5 Surge 3.0 A (8/20 µs)
	EMC filter	X2Y filters on all inputs
	Channel to channel crosstalk	-80 dB
	Temperature error (@-10 ÷ 30 °C)	<ul style="list-style-type: none"> Scale: 300 ÷ 1200 mV < ±0.01 % FS Scale: ±39 mV < ±0.01 % FS Scale: ±78 mV < ±0.01 % FS

Digital inputs	Inputs number	4
	Mode	4 inputs for frequency/counters/logic state On-Off (0 ÷ 3 Vdc) of which: <ul style="list-style-type: none"> 2 inputs for sensors with optoelectronics (freq. max 10 kHz) 2 frequency inputs (max 5 kHz)
	Max. input freq.	5 kHz
	Accuracy	3 Hz @5 kHz
	Protections (power supply)	Potenza di picco dell'impulso: <ul style="list-style-type: none"> 600 W (10/1000 µs) 4 kW (8/20 µs)
	Protections (complies standards)	<ul style="list-style-type: none"> IEC 61000-4-2 level 4: <ul style="list-style-type: none"> 15 kV (air discharge) 8 kV (contact discharge) IEC 61000-4-5 MIL STD 883G, method 3015-7: class 3B <ul style="list-style-type: none"> 25 kV HBM (human body model)

Switched power supply outputs	Number	7 (with programmable switching-on time before sensor acquisition)
	Max. current	1.1 A per output (7.7 A total for all outputs)
	Voltage clamping	33 V
	Protections	On each output: PTC PTC overcurrent protections (resettable) max. 1.1 A
	Protections (power supply)	Peak pulse power: <ul style="list-style-type: none"> 600 W (10/1000 µs) 4 kW (8/20 µs)
	Protections (complies standards)	<ul style="list-style-type: none"> IEC 61000-4-2 level 4: <ul style="list-style-type: none"> 15 kV (air discharge) 8 kV (contact discharge) IEC 61000-4-5 MIL STD 883G, method 3015-7: class 3B <ul style="list-style-type: none"> 25 kV HBM (human body model)

Power supply	Power supply	8 ÷ 30 Vdc
	Consumo @12V	During acquisition: 115 mW Stand-by: <4 mW
	Voltage clamping	33 V
	Protections	From reverse polarity
	EMC filter	YES (AEC-Q200)
	Protections (power supply)	Peak pulse power: <ul style="list-style-type: none"> • 600 W (10/1000 µs) • 4 kW (8/20 µs)
	Protections (complies standards)	<ul style="list-style-type: none"> • IEC 61000-4-2 level 4: <ul style="list-style-type: none"> ○ 15 kV (air discharge) ○ 8 kV (contact discharge) • IEC 61000-4-5 • MIL STD 883G, method 3015-7: class 3B <ul style="list-style-type: none"> ○ 25 kV HBM (human body model)

RS-232 serial ports	Number	2 (1 for ELO3305.1 and ELO3515)
	Interface	DB9 female (DCE)
	Speed	1200 ÷ 115200 bps
	Data bits, Parity, Stop bits	8, None, 1 (not changeable)
	How to use	<ul style="list-style-type: none"> • Serial port 1: <ul style="list-style-type: none"> ○ Connection to PC ○ Connessione to communication systems (2G/3G modem, radio) • Serial port 2: <ul style="list-style-type: none"> ○ Connection to SCADA/PLC systems (Modbus RTU® protocol) ○ Connection ti sensore with different protocol types (Biral, Boschung, Climatronics, Gill, Lufft and others) ○ Connection to lightning sensor (DQA601.1)

RS-485 serial port	Number	1 (only ELO3305.1)
	Interface	DB9 female
	Speed	1200 ÷ 115200 bps
	Data bits, Parity, Stop bits	8, None, 1 (not changeable)
	How to use	Connection to SCADA/PLC systems (Modbus RTU® protocol)
	Power supply	Isolated 12 V @160 mA

Miscellaneous	Standard protection	EN 61326-1 2013, EN 61010-1 2013, EN 50581 2013
	Watch	Accuracy: 30 s/month (@ 25°C)
	Keyboard	8 membrane keys
	Processor	2 RISC 8 bit, clock 16 MHz
	A/D converter	18 bit resolution (rounded to 16 bit)
	Sample duration	(rejection 50/60 Hz): 80 ms@rejection 50 Hz
	Data memory	Flash EEPROM 8 Mb
	Environ. limits	-30÷70 °C, 15÷100 % RH (without water condensation)
	Physical protections	onformal coating on the electronic board to protect the board's components against moisture, dust, chemicals, and temperature extremes
	Protection grade	IP 40
	Weight	720 g
	Dimensions	242 x 108 x 80 mm

6.2 Function library for derived calculations

E-Log has a useful library containing deriving quantities, featuring application functions dedicated to both indoor (microclimate) and outdoor (meteorology) environmental sectors.

The list below shows all calculation functions available:

- **Arithmetical calculations**
 - Addition-summation
 - Subtraction
 - Multiplication
 - Division

- **Statistical/mathematical operations**
 - Integral
 - Mean
 - Power
 - Exponential
 - Natural logarithm and base 10
 - Square root

- **Mobile calculations**
 - Minimum, average, maximum
 - Totalization
 - Angular average

- **Thermo-hygrometric quantities (UNI EN ISO 7726, ISO/WD 7730, VDI 3786)**
 - Relative humidity with psychrometric calculation (dry/humid bulb)
 - Absolute humidity
 - Specific humidity
 - Mixing factor (ratio)
 - Humid air enthalpy
 - Dew point temperature
 - Partial steam pressure
 - Humidity index (HI)
 - Discomfort of heat index
 - Indoor and outdoor WBGT index
 - Wind chill index
 - Chill temperature (TCH)
 - Mean radiant temperature
 - Radiant temperature asymmetry
 - Average planar radiant temperature
 - Planar temperature side 1 and side 2
 - Percentage of dissatisfied people due to radiant temperature asymmetry from wall or ceiling
 - Dissatisfied floor temperature
 - Dissatisfied vertical temperature
 - Draught rating
 - Operative temperature

- **Duct flow**
 - Air speed from differential pressure (Pitot or Darcy)
 - Volumetric air and mass flow
 - Number of air changes

- **Radiometry**
 - Insolation time
 - UV index (DLE)
 - UV exposure level
 - Light intensity
 - UVA density
 - Day light factor

- **Actuators operations(*)**
 - Actuation status calculated with AND operator
 - Actuation status calculated with OR operator
 - Actuation logics status calculated with AND operator
 - Actuation logics status calculated with OR operator

- **Others**
 - Evaporation calculation based on the evaporimeter level
 - Soil volumic humidity with permittivity
 - Atmospheric pressure at sea level
 - Total count
 - Delta with previous value
 - Reprocess measure
 - Correct level

(*) Calculated measures available only for E-Log data logger with firmware from 2.13.1 version; calculated measures associated with 3DOM software from 3.8 version.

These measures are set a fixed update time of 1 second: the update of value of calculated measure on the actuator is always 1 second delay compared to the status recorded by internal actuation logic.

Now is therefore possible to process and record the actuator status or display it as an instantaneous value without having to carry the electrical signal of the actuator in an input of the data logger. Now it is also possibly make complex algorithms through a combination of actuation logics status with other calculated measures (typically addition and multiplication), overcoming the limits of the use of a single operator (AND and OR) and giving the inputs for the acquisition of real sensors.

With *3DOM* you can choose which quantities to have the instrument calculate and select the direct measures which allow their calculation.

Some calculations, frequently used in agro-meteorology, such as wind direction or integral radiation, are easily obtained from the integral mathematical calculation.

6.3 Error messages

E-Log indicates errors by triggering the red led *Err* located on the instrument's keyboard: the kinds of errors, listed in the following table, are indicated by the blinking modes.

Number of blinkings	Type of problem	Troubleshooting
1	Data memory access	Try to transfer the data elaborated by the instrument; then send the configuration again to the instrument using <i>3DOM</i> (see §3.1.5); if the error occurs again, contact LSI LASTEM technical support
2	IPC	Transfer the data elaborated by the instrument; then switch the instrument off (before) and on (after); if the error remains after many attempts, contact LSI LASTEM technical support
3	Acquisition from sensors	Use <i>3DOM</i> to check the congruence of the acquisition parameters of the measures in the current configuration; send the configuration again to the instrument (see §3.1.5); should a new error occur, contact LSI LASTEM technical support for assistance including the current configuration file
4	Parameter configuration	Transfer the data elaborated by the instrument; then send the configuration again to the instrument using <i>3DOM</i> (see §3.1.5); if the error occurs again, contact LSI LASTEM technical support for assistance including the current configuration file
5	Search data in memory	If the error occurs immediately after switching on the instrument, reset the error and continue using the instrument as usual; should a new error occur while operating the instrument with no communication with the PC, contact LSI LASTEM technical support; should the error occur while requesting the elaboration in memory by the program <i>3DOM</i> , try requesting the data again using a different date/time (try using a previous date first; should a new error occur, try later dates); should the error persist, switch the instrument on and off and request all data indicating a date/time definitely prior to the first date in memory; upon completion of the data transfer, cancel them; should the error occur again send the configuration of the instrument to LSI LASTEM technical support describing the problem
6	Protocol CISS	Use <i>3DOM</i> to check the congruence of contents parameters in the current configuration; send the configuration again to the instrument (see §3.1.5); should a new error occur, contact LSI LASTEM technical support for assistance including the current configuration file

When the instrument finds an error, it also indicates it as follows:

- 1) By activating the digital signal of the error;
- 2) By displaying the numeric value of the error found: the error code appears on the visualization window of the diagnostic data type 1 (see §4.3.3); the numeric code can actually indicate more than one error; the displayed value is expressed with a hexadecimal number; the errors that correspond to the value that appears on the display can be easily interpreted by means of program *3DOM* (menu *Instruments*);
- 3) By communicating with program *3DOM*: while the instrument transfers the elaborations or sends the configuration data, the programs may show the code of the error found by the instrument.
- 4) By sending of system operating state through other communication protocols (i.e. TTY e Modbus).

6.3.1 Disabling error indication

There are two possibilities to disable error indication:

- 1) Press key [F2] while the error code is being displayed in the diagnostic window type 1 to reset the error (it will however remain on the display when you leave and call the diagnostic window);
- 2) While the data is being transferred between instrument and PC: in this case the instrument resets the error since it considers that the error has already been found by the person using the computer.

In both cases the reset operation will locally switch off the optical indicator *Err*, eliminate the error number from the diagnostic window type 1 and disable the signal in effector's output (if programmed by respective actuation logic). The error reset will remain until the instrument finds a new possible error; in this case the instrument will activate the error indication mode again as previously described.

6.3.2 Error found in measure

The values indicated by the measures (instantaneous values) may indicate the error status (*Err*), in the following conditions:

- If the measure is acquired:
 - Programming of a measure incompatible with the type of signal to be measured (electrical type selected, linearization type, scale recalculation parameter, etc.);
 - Sensor is interrupted or is not correctly connected to the terminal board (see §3.1.1);
 - If the sensor is powered by an energized output, the starting time might not be enough;
 - The electrical input signal (to the instrument) is out of scale;
 - In case of thermocouple measure, the cold junction temperature (internal temperature) might not be programmed;
 - In case of measure acquired from serial port: no valid message has been detected coming from the sensor during time corresponding to more than treble set acquisition rate.
- If the measure is calculated:
 - Out-of-scale or in-error value from one or more dependant measures allocated to the measure to be calculated;
 - Error in output to the algorithm of the calculated measure;

When the number to be displayed is < -999999 or > 9999999 , E-Log points out the anomaly of measure in overflow with "Overfl." error status.

6.4 Instrument maintenance

E-Log does not require special maintenance interventions when installed according to the general safety rules indicated in §1.

However, we recommend that LSI LASTEM staff carries out periodical check of whole installation (E-Log and sensors connected to it) at regular intervals in order to point out and correct possible measurement errors.

6.5 Mask of terminal board

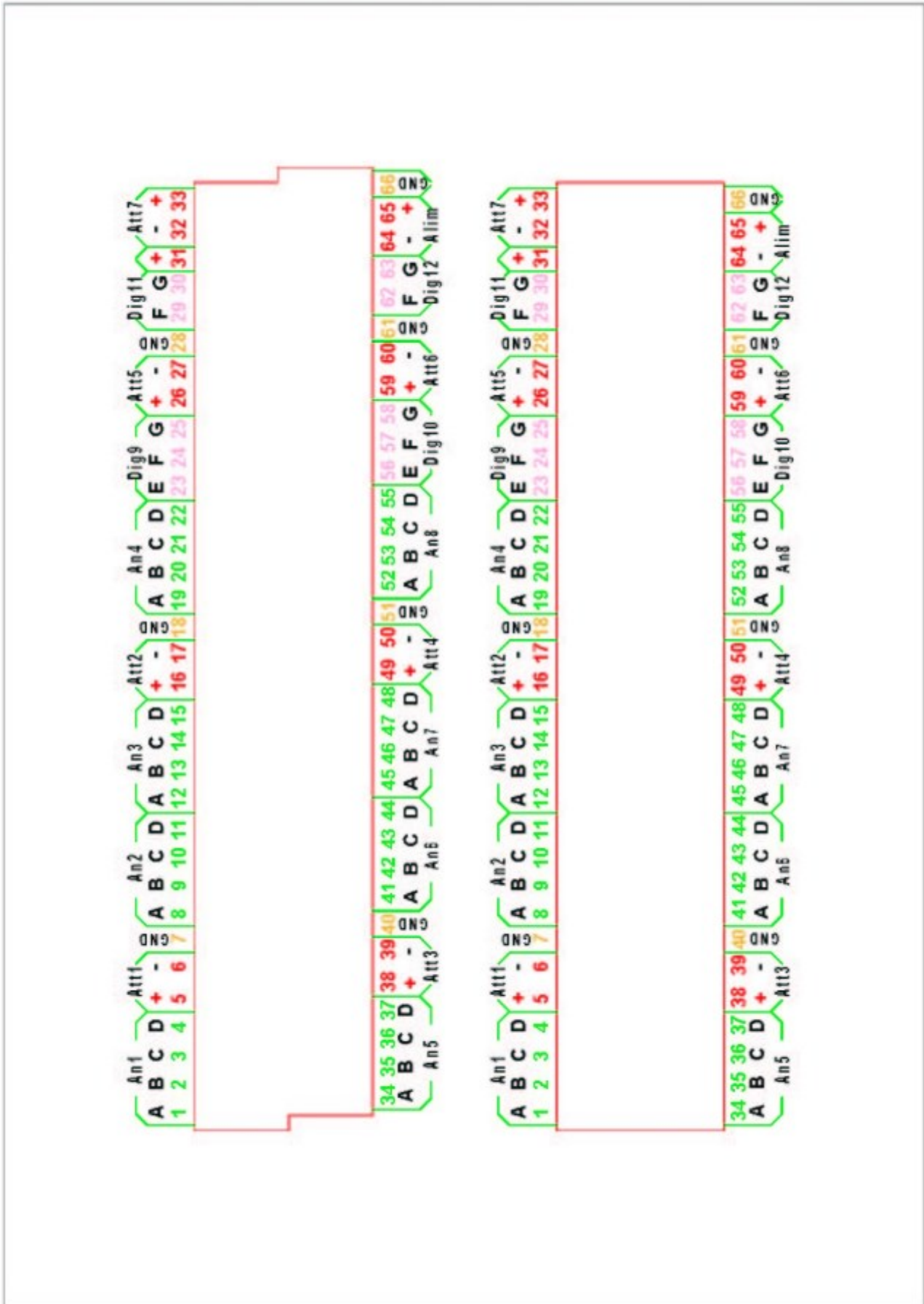

6.6 Connection cables

ELA115
CAVO DI RACCORDO SENSORI ANALOGICI
ANALOGUE SENSORS CONNECTION CABLE

300

CONNETTORE MINIDIN FEMMINA 7C
7C FEMALE CONNECTOR

PIN	COLOR
1	NERO/BLACK
2	ROSSO/RED
3	GIALLO/YELLOW
4	VERDE/GREEN
5	BIANCO/WHITE
6	MARRONE/BROWN
7	BLU/BLUE

CANALI E-Log CHANNELS	SEGNALI ANALOGICI ANALOGUE SIGNALS				ALIMENTAZIONE 12V POWER SUPPLY	
	NERO BLACK	ROSSO RED	GIALLO YELLOW	VERDE GREEN	MARRONE BROWN	BLU BLUE
1	1	2	3	4		
2	8	9	10	11	5+	8-
3	12	13	14	15		
4	18	20	21	22	18+	17-
5	34	35	33	37		
6	41	42	43	44	38+	36-
7	45	46	47	48		
8	52	53	54	55	48+	50-

N° DEL MORSETTO UTILIZZABILE SU E-Log
TERMINAL NUMBER USABLE ON E-Log

P									
A									
Origine	20 05 00	A.A.		000	A.P.	Descrizione della revisione			
Cap. di revisione	000	CR	CR	CR	CR	Materiale:			
Scala:								Codice	Dis. D
Descrizione:									D SACC 517 2

CAVO DI RACCORDO BABUC A.M - E-Log
CONNECTION CABLE BABUC A.M - E-Log

Cod. ELA117
CAVO DI RACCORDO SENSORI IMPULSIVI
PULSE SENSORS CONNECTION CABLE

300

CONNETTORE MINIDIN FEMMINA 4C
4C FEMALE CONNECTOR

PIN	COLOR
1	MARRONE/BROWN
2	NERO/BLACK
3	BLU/BLUE
4	N.C.

CANALI E-Log CHANNELS	SEGNALI IMPULSIVI PULSE SIGNALS		
	MARRONE BROWN	NERO BLACK	BLU BLUE
8	23	24	25
10	56	57	58

N° DEL MORSETTO UTILIZZABILE SU E-Log
TERMINAL NUMBER USABLE ON E-Log

ESEMP. DI APPLICAZIONI PARTICOLARI
EXAMPLES OF SPECIAL APPLICATIONS

FOTORELEVAZIONE
PHOTO-RELEVATOR

CONTATTO NORM. APERTO
NORM. OPEN CONTACT

P									
A									
Origine	10 05 00	A.A.		000	A.P.	Descrizione della revisione			
Cap. di revisione	000	CR	CR	CR	CR	Materiale:			
Scala:								Codice	Dis. D
Descrizione:									D SACC 517 4

CAVO DI RACCORDO BABUC A.M - E-Log
CONNECTION CABLE BABUC A.M - E-Log

6.7 Supported protocols

Protocol ⁽⁵⁾	E-Log std	E-Log P1 ⁽³⁾	E-Log P2 ⁽³⁾	E-Log P4 ⁽³⁾
CISS (Com1 e Com2)	X	X	X	X
TTY	X	X	X	X
ZigBee	X ⁽¹⁾			X
Modbus RTU slave	X	X	X	X
Modbus RTU master	X	X	X	
Gill		X		
Climatronics				
Biral				X
Hydrolab		X		
Aeroqual		X		
Lufft ⁽⁷⁾			X	
Boschung			X	
Giletta			X	
GPRS TTY ASCII (Com1)	X	X	X	X

⁽¹⁾ Only on models with radio; excludes the presence of all other protocols, except CISS.

⁽³⁾ Only model ELO305.

⁽⁴⁾ Only model ELO008.

⁽⁵⁾ Where not specified, only on Com2.

⁽⁷⁾ Available on E-Log up to V. 2.40.05.